

# GSI 61

## Clinical Audiometer

---

### User Manual

Model Numbers:

1761-9700-XXE

1761-9780-XXE



User Manual 1761-0100, Rev 12  
Revised July, 2005

---

Grason-Stadler - A Division of VIASYS Healthcare  
5225 Verona Road, Building 2, Madison, WI 53711  
TEL: 608-441-2323, 800-700-2282, FAX: 608-441-2234

**VIASYS**<sup>TM</sup>  
HEALTHCARE  
*Excellence For Life*

# Electromagnetic Compatibility (EMC)

---

---

## Electromagnetic compatibility (EMC)

Please refer to the Electromagnetic Compatibility Reference Guide on CD (part number 482-6387xx) for EMC information concerning your system.

---

## Compatibilité électromagnétique (CEM)

Veillez vous reporter au guide de référence de compatibilité électromagnétique sur CD (numéro de pièce 482-6387xx) pour des informations sur la CEM relatives à votre système.

---

## Elektromagnetische Verträglichkeit (EMV)

Informationen über die EMV des Systems finden Sie im Referenz-Handbuch Elektromagnetische Verträglichkeit auf der CD (Teilenummer 482-6387xx).

---

## Compatibilità elettromagnetica (EMC)

Verdere la guida alla consultazione per la compatibilità elettromagnetica contenuta sul CD (numero di parte 482-6387xx) per informazioni sulla compatibilità elettromagnetica relativa al sistema in dotazione.

---

## Compatibilidad electromagnética (CEM)

Consulte la Guía de referencia sobre compatibilidad electromagnética incluida en el CD (número de pieza 482-6387xx) para obtener la información sobre la CEM de su sistema.

---

## Electromagnetic compatibility (EMC)

Please refer to the Electromagnetic Compatibility Reference Guide on CD (part number 482-6387xx) for EMC information concerning your system.

---

## 电磁兼容性 (EMC)

有关系统的 EMC 信息，请参阅 CD 上的电磁兼容性 (EMC) 参考指南 (部件号 482-6387xx)。

---

## 電磁適合性 (EMC)

お使いのシステムに関する EMC 情報については、CD (パーツ番号 482-6387xx) の『電磁適合性 (EMC) リファレンスガイド』を参照してください。

---

## 전자파적합성 (EMC)

시스템에 관한 EMC 정보는 CD의 『전자파적합성(EMC) 가이드』 (부품 번호: 482-6387xx)를 참조하십시오.

---

## Compatibilidade Eletromagnética (EMC)

Favor consultar o Guia de Referência à Compatibilidade Eletromagnética no CD (número de peça 482-6387xx) para informações da EMC relativas ao seu sistema.

# Warranty

---

We, Grason-Stadler, warrant that this product is free from defects in material and workmanship and, when properly installed and used, will perform in accordance with applicable specifications. If within one year after original shipment, it is found not to meet this standard, it will be repaired, or at our option, replaced at no charge except for transportation costs, when returned to an authorized Grason-Stadler facility. If field service is requested, there will be no charge for labor or material; however, there will be a charge for travel expense at the service center's current rate.

**Note:** Changes in the product not approved in writing by Grason-Stadler shall void this warranty. Grason-Stadler shall not be responsible for any indirect, special or consequential damages, even if notice has been given in advance of the possibility of such damages.

**THIS WARRANTY IS IN LIEU OF ALL OTHER WARRANTIES, EXPRESSED OR IMPLIED, INCLUDING BUT NOT LIMITED TO, ANY IMPLIED WARRANTY OF MERCHANTABILITY OR FITNESS FOR A PARTICULAR PURPOSE.**

## Revision History

### GSI 61 User Manual 1761-0100

<u>Date</u>	<u>Rev.</u>	<u>Change Order</u>
July 2005	12	DCO-
February 2005	11	DCO-0302
September 2003	10	DCO-0287
August 2003	9	1761-0194
March 2003	8	DCO-0279
January 2003	7	1761-0188
February 1999	6	DCO-0144
February 1998	5	DCO-0099
November 1996	4	1761-0115
March 1996	3	1761-0060
February 1996	2	1761-0051
January 1996	1	1761-0038

Blank page.

# Contents

---

## Preface

- Electromagnetic Compatibility (EMC)** ----- 2
- Warranty** ----- i
- Revision History ----- i
- Specifications** ----- i
  - Standards ..... i
  - Pure Tone - Channel 1 and Channel 2 ..... i
  - Speech Channel 1 and Channel 2 ..... ii
  - Signal Format ..... ii
  - Special Test Capabilities ..... ii
  - Communications and Monitoring ..... ii
  - Dimensions and Weight ..... ii
  - Power Consumption ..... iii
  - Accessories Supplied ..... iii
  - Optional Accessories ..... iii
  - Catalog Listings ..... iv

## Chapter 1

### Introduction

- Introduction** ----- 1-1

## Chapter 2

### Installation

- Installation** ----- 2-1
  - External Inspection ----- 2-1
  - Unpacking ----- 2-1
  - Accessories Supplied ----- 2-1
  - Connectors, Controls and Indicators ----- 2-2
  - Rear Panel ----- 2-2
  - Left Side Panel ----- 2-4
  - Right Side Panel ----- 2-4
  - Front Panel Controls ----- 2-5
    - Valid Stimuli Combinations ..... 2-8
    - Valid Transducer Combinations ..... 2-8
    - Displays ..... 2-10
  - Test Microphone/Monitor Headset ----- 2-17
  - Optional Accessories ----- 2-18
  - Hearing Level And Frequency Limits ----- 2-24
  - Initial Installation ----- 2-26
    - Two Room Installation ..... 2-27
    - Loudspeaker Installation ..... 2-29
- Operation** ----- 3-1
  - Preliminary Checks ----- 3-1

## Chapter 3 Operation

Patient Instructions -----	3-2
Placement of the Earphones .....	3-2
Placement of the Insert Phone .....	3-2
Placement of the Bone Vibrator .....	3-2
Routine Test Procedures -----	3-3
Threshold Determination (Pure Tone): Modified Hughson-Westlake .....	3-3
Spondaic Speech Testing, Speech Reception Threshold (SRT) .....	3-4
Speech Discrimination (PB Words) .....	3-4

## Chapter 4 Special Test Procedures

<b>Special Test Procedures -----</b>	<b>4-1</b>
Alternate Binaural Loudness Balance (ABLB) or Fowler Test -----	4-2
Monaural Loudness Balance (MLB) Test -----	4-3
Short-Increment Sensitivity Index (SISI) -----	4-4
Modifications to the SISI test .....	4-4
High Frequency Testing (Optional) -----	4-5
High Frequency Testing: Setup Diagrams .....	4-5
Sensorineural Acuity Level (SAL) Test -----	4-6
Hearing Aid Evaluation -----	4-6
Tone Decay Test -----	4-8
Lombard or Voice-Reflex Test -----	4-8
Delayed Auditory Feedback (DAF) -----	4-9
Staggered Spondaic Word Test (SSW) -----	4-10
Doerfler-Stewart Test -----	4-11
Modified Doerfler-Stewart Test .....	4-11
Pure Tone Stenger Test -----	4-12

## Chapter 5 Routine Maintenance

<b>Routine Maintenance -----</b>	<b>5-1</b>
Biological Calibration Check -----	5-1
Periodic Checks -----	5-1
Calibration Reference Levels -----	5-3
Line Voltage Brownout and Interruptions -----	5-6

# Chapter 6

## Remote (RS232 ) Option

<b>Remote (RS 232) Option</b> .....	<b>6-1</b>
Data Flow Control Operation .....	6-3
Hardware Flow Control .....	6-3
Software Flow Control .....	6-3
Cable Connections .....	6-3
Data Transfer .....	6-4
Record and Field Formatting .....	6-4
Checksums .....	6-4
Remote Input Operation .....	6-5
Input Record Type .....	6-5
Input Record Type 1 to 4 .....	6-5
Input Record Type 5 - Pushbutton Code Record .....	6-5
Input Record .....	6-9
Type 6 - Set Test Frequency Record .....	6-9
Type 7 - Set HL Record .....	6-10
Remote Output Operation .....	6-11
Output Record .....	6-11
Type 1 - GSI 16 Compatible Short Data Record .....	6-11
Output Record .....	6-13
Type 4 - Error Record .....	6-14
Type 5 - GSI 61 Short Data Record .....	6-14
Type 6 - Test Battery Data Record .....	6-16
Record Prefix .....	6-16
Left Ear Test Data - Pure Tone .....	6-16
Speech Test .....	6-18
SISI Test .....	6-18
Alternate (ABLB) .....	6-20
Right Ear Test Data .....	6-21
Record Terminator .....	6-21
Type 7 - Instrument Type .....	6-21
Remote Output Operation continued .....	6-22
Output Record .....	6-22
Type 8 - Unit Configuration Record .....	6-22

# Chapter 7

## Warnings, Cautions, and Errors

<b>Warnings, Cautions and Errors</b> .....	<b>7-1</b>
Warnings .....	7-1
Cautions .....	7-1
Status Messages .....	7-2
Communications Error Messages .....	7-2

# Chapter 8

## Bibliography

<b>Bibliography</b> .....	<b>8-1</b>
Bibliography for Test Procedures .....	8-2

# Appendix

<b>Test Words</b> .....	<b>A1-1</b>
Part One .....	A1-1
Part Two .....	A1-1

Blank page.

# Specifications

## Standards

The GSI® 61 Clinical Audiometer meets or exceeds the following standards: ANSI S3.6-1989; ANSI S3.43-1992; IEC 645-1 (1992); IEC 645-2 (1993); ISO 389; UL 2601-1 Medical Electrical Equipment; IEC 601-1 Medical Electrical Equipment and CSA C22.2, No. 601.1-M90 Electromedical Equipment.

The CE mark on this product indicates it conforms with the provisions noted in the 93/42/EEC Medical Devices Directive.

 CE Mark per Medical Device Directive (93/42/EEC)

0344

### European Representative:

VIASYS Healthcare  
Welton Road  
Warwick  
CV34 5PZ  
U.K.

## Pure Tone - Channel 1 and Channel 2

### Frequency Range

Air Conduction	125 Hz to 12000 Hz
High Frequency (optional)	8 kHz to 20 kHz
Bone Conduction	250 Hz to 8000 Hz
Sound Field (optional)	125 Hz to 12,000 Hz (125 Hz to 16,000 Hz only with High Frequency option, 1761-9630, enabled)
Paired Insert (optional)	125 Hz to 8000 Hz
Single Insert (optional)	250 Hz to 6000 Hz
Accuracy	± 1 %
Total Harmonic Distortion	£ 2% (earphones and paired insert phones*) £ 5% (bone vibrator)

### Intensity Range \*\*

Air Conduction:	-10 dB HL to 120 dB HL
High Frequency:*	-20 dB HL to 100 dB HL (with Sennheiser HDA 200 Phones)
Bone Conduction:	
Mastoid	-10 dB HL to 80 dB HL
Forehead	-10 dB HL to 70 dB HL
Sound Field:*	-10 dB HL to 96 dB HL
Paired Inserts:*	-10 dB HL to 110 dB HL
Single Insert:*	-10 dB HL to 110 dB HL

### Masking Intensity Range (Calibrated in effective masking)

Narrow Band Noise:	Maximum dB HL is 15 dB below tone
White Noise:	Maximum dB HL is 30 dB below tone

\* *Optional accessories*

\*\* *The maximum HL values are applicable to the middle frequencies only.*

*GSI® 61 is a registered trademark of Grason-Stadler. All rights reserved.*

**Speech Channel 1 and Channel 2**

Microphone: For live voice testing and communications  
 External A and External B: Accepts recorded speech material from external stereo tape cassette or CD player

Intensity Range:  
 Air Conduction: -10 dB HL to 105 dB HL  
 Bone Conduction:  
     Mastoid -10 dB HL to 65 dB HL  
     Forehead -10 dB HL to 55 dB HL  
 Sound Field:\*\*\* -10 dB HL to 90 dB HL  
 Paired Inserts:\*\*\* -10 dB HL to 95 dB HL  
 Single Insert:\*\*\* -10 dB HL to 95 dB HL

Masking Intensity Range  
 Speech Noise:  
     Air Conduction (TDH 50P and Insert Phones\*) and Bone Conduction  
     Maximum dB HL are the same as the speech type signals.  
     Sound Field: -10 dB HL to 80 dB HL  
 White Noise: Equal to Speech Noise

\*\*\* *Optional Accessories*

Steady: Tone continuously present.  
 Pulsed: Tone pulsed 200 mSec ON, 200 msec OFF.  
 FM: Tone modulated ± 5% of center frequency at a rate of 5 Hz.

**Signal Format**

ALT: Tone alternating between Channel 1 and Channel 2: Channel 1 is 400 mSec ON, 400 mSec OFF followed by Channel 2, 400 mSec ON, 400 mSec OFF.

**Special Test Capabilities**

SISI: An intensity increment is added to a tone in the selected channel for 200 mSec, every 5 seconds. The HL increments are available in 1, 2 or 5 dB steps.  
 High Frequency: Tone testing in the frequency range of 8 kHz to 20 kHz using High Frequency phones or Sound Field. The frequencies available for testing are: 8 kHz, 9 kHz, 10 kHz, 11.2 kHz, 12.5 kHz, 14 kHz, 16 kHz, 18 kHz and 20 kHz (Optional).

**Communications and Monitoring**

Talk Forward: Permits the tester to speak through the test microphone into the selected transducer at the intensity level set by the front panel controls.  
 Talk Back: Allows the tester to listen to comments from the subject in the testing booth.  
 Monitor: The monitor headset or monitor speaker can be used by the tester to listen to Channel 1, Channel 2 and/or Talk Back signals.

**Dimensions and Weight**

W x D x H: 20 inches x 15 inches x 12.6 inches (LCD raised)  
 50 cm x 39 cm x 32 cm  
 Height with LCD lowered - 6 inches (15 cm)  
 Weight: 19 pounds 8.7 kg  
 Shipping Weight: 30 pounds 13.6 kg

<b>Power Consumption</b>	90 Watts	
<b>Accessories Supplied</b>	Test Headset (Matched set TDH-50P) -----	8000-0063
	Bone Vibrator (B71) -----	8000-0130
	Subject Response Handswitch -----	7874-0156
	Test Microphone/Monitor Headset with coiled cord -----	1761-9623
	Talk Back Microphone -----	8000-0039
	Patch Cords, 6 ft. Grey (4/each) -----	4204-0505
	Power Cord -----	(Country and voltage specific)
	Instruction Manual - English -----	1761-0100
	Instruction Manual - Spanish -----	1761-0104
<b>Optional Accessories</b>	CD Player -----	1761-9621
	Stereo Tape Cassette -----	1761-9622
	Speakers, Basic (90 dB) with cables (125 - 16 kHz) -----	1761-9630
	Speakers, High Performance (96 dB) with cables (125 - 8 kHz) -----	1761-9635
	Booster Amplifier (220-240V) with cables, for use with the High Performance Speakers only -----	1761-9636
	Booster Amplifier (100-120V) with cables, for use with the High Performance Speakers only -----	1761-9637
	Sound Field System, High Performance (102 dB, 220-240V, 125 - 8 kHz) includes High Performance Speakers and Booster Amp -----	1761-9638
	Sound Field System, High Performance (102 dB, 100-120V, 125 - 8 kHz) includes High Performance Speakers and Booster Amp -----	1761-9639
	Paired Insert Phones (E•A•RTONE™ 3A) -----	1700-9606
	E•A•RTONE™ Replacement Foam Eartips, Std -----	1700-9604
	E•A•RTONE™ Replacement Foam Eartips, Small -----	1700-9605
	Single Insert Phone (470) -----	1700-9609
	High Frequency Headphones w/booth cables -----	1761-9602
	High Frequency Cables (to sound booth) -----	1761-9603
	(If you already have High Freq Headphones, you need these cables to connect to the GSI 61.)	
	High Frequency Headphones w/cables to GSI 61 -----	1761-9604
	High Frequency Cables (to GSI 61) -----	1761-9605
	(If you already have High Freq Headphones, you need these cables to connect to the GSI 61.)	
	Remote RS 232/Printer Interface -----	1761-9680
	Printer, Color (North America only) -----	1761-9610
	Service Manual -----	1761-0110
	Audiocups -----	8000-0155

**Catalog Listings**

GSI 61 Clinical Audiometer without RS 232

English -----	1761-9700-XXE
French -----	1761-9700-XXF
German -----	1761-9700-XXG
Italian -----	1761-9700-XXI
Spanish -----	1761-9700-XXS

GSI 61 Clinical Audiometer with RS 232

English -----	1761-9780-XXE
French -----	1761-9780-XXF
German -----	1761-9780-XXG
Italian -----	1761-9780-XXI
Spanish -----	1761-9780-XXS

**Notes** -XX refers to the voltage and plug requirements for the country of operation.

# Introduction

# 1



The GSI 61 Clinical Audiometer is a microprocessor controlled, two channel audiometer for use in the clinical/diagnostic environment. It has two separate sets of controls, one for each of the channels. Each channel can be operated independently by its tone bar, or the two channels can be activated simultaneously through use of the interlock button.

The GSI 61 permits the output routing of the test signal through earphones (matched TDH-50P), a bone vibrator (B71), optional loudspeakers, optional paired Insert Phones (EAR) or single Insert Phone, and optional High Frequency (Sennheiser HDA 200) Earphones.

The diagnostic tests are easily selected through use of the ergonomically designed front keypad. Flexible routing selections permit the user to select that which is appropriate

for the test sequence. The Tracking pushbutton allows the operator to synchronize intensity changes on Channel 2 with those made on Channel 1.

All data, including the instrument selected parameters, are displayed on an articulating Liquid Crystal Display (LCD). Pure tone test results are presented in either a "status" or an audiogram format. The status format clearly shows all test conditions and permits the calibration check of input from the microphone or from recorded test materials. The audiogram format for pure tone testing displays the stored threshold values for the patient under test. The display can be tilted to improve the viewing angle for an individual user and to allow easy access to the rear jack panel.

The GSI 61 provides testing capabilities for a standard battery of diagnostic audiometric tests including ABLB, SISI, Tone Decay, Stenger, Doerfler-Stewart, Lombard, and Staggered Spondaic Word test (using a three head tape recorder). The High Frequency option extends the frequency range (from 8 kHz to 20 kHz) for ototoxic drug monitoring.

The GSI 61 has the optional capability of printing the stored audiogram data or of sending the data to a remote computer through an RS 232 interface. The RS 232 interface is bidirectional to allow the operator to transmit test results to a computer and to control the audiometer from a remote computer system. The transmittable data record can be configured to be either a single value (threshold and frequency) or battery transfer (all stored parameters for a patient).

Blank page.

# Installation

# 2

## External Inspection

Although your GSI 61 Clinical Audiometer was carefully tested, inspected and packed for shipping, it is a good practice after receiving the instrument to immediately examine the outside of the container for any signs of damage. Notify your carrier if any damage is observed.

## Unpacking

Carefully remove your GSI 61 from its shipping container. If the instrument appears to have suffered mechanical damage, notify the carrier immediately so that a proper claim can be made. Be certain to save all packing material so that the claim adjuster can inspect it as well. As soon as the carrier has completed the inspection, notify your Grason-Stadler representative.

If the instrument must be returned to the factory, repack it carefully (in the original container, if possible) and return it prepaid to the factory for the necessary adjustments.

Check that all accessories itemized below are received in good condition. If any accessories are missing, your Grason-Stadler representative should be notified immediately.

See the Specifications Section of this manual for the catalog numbers of accessories and also for a listing of the optional accessories.

## Accessories Supplied

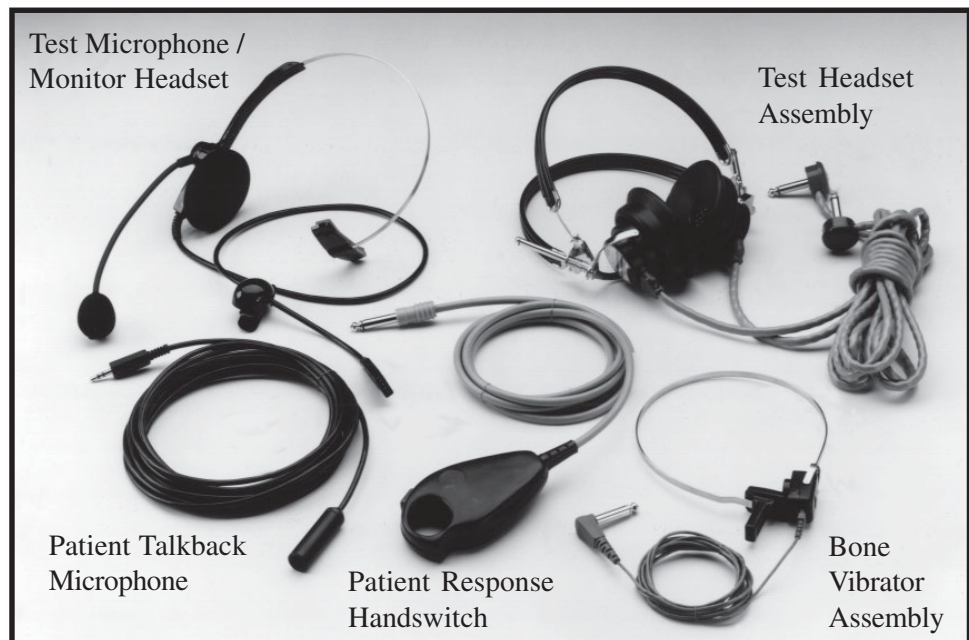

**Not Shown:** *For Sound Booth use:* Handswitch Patch Cord (1)  
Bone Vibrator Patch Cord (1)  
Earphone Patch Cord (2)  
*Other:* Instruction Manual.....Power Cord

# Connectors, Controls and Indicators

## Rear Panel

The connectors on the rear panel of the GSI 61 are shown in the following diagram. The label and jacks are visible looking down onto the instrument, behind the LCD.

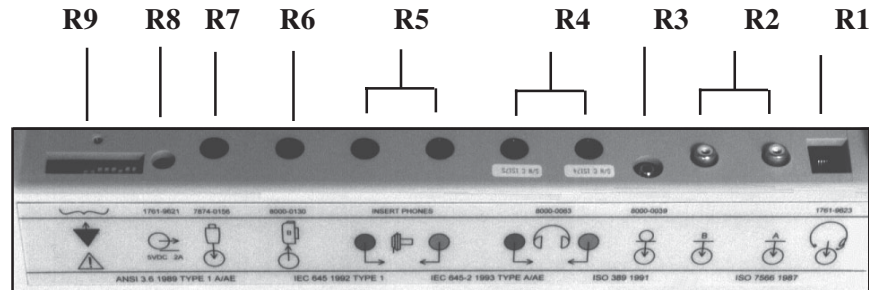

### R1 - Monitor Headset (Modular Phone Jack)

Pin	Function	Output Voltage	Impedance
1	Mic High and +6 VDC	0.2 to 6.0 mV RMS	1.8 K ohm (output)
2	Phone Low	GND	0 ohm
3	Phone High	3.0 mV to 1.0 V	300 ohm
4	Mic Shield	GND	0 ohm

### R2 - Ext A and Ext B (RCA plug)

Input jacks for optional stereo tape cassette or CD player.  
**Voltage range required:** 0.2 to 1.0 V to obtain 0 VU  
**Input Impedance:** 15 K ohm

### R3 - Talkback Microphone (3.5 mm stereo jack)

Position	Function	Output Voltage	Impedance
1 Tip	Mic High	0.2 to 2.0 mV RMS and +6V AC	10 K ohm
2 Ring	Mic Low	-----	-----
3 Shield	Chassis Ground	-----	-----

### R4 - Left and Right Ear Phone Outputs (1/4 inch stereo jack)

Stereo phone jacks for left (blue) and right (red) earphones, patch cords, or High Frequency earphone connector cords.  
**Voltage:** 1µV to 7.0 V RMS (4.45 V RMS for High Frequency)  
**Output impedance:** 5 ohms or less

### R5 - Left and Right (1/4 inch monaural jack)

**Insert Phone Outputs**

Monaural phone jacks for left and right insert phones or patch cords.

**Voltage:** 1 $\mu$ V to 4.0 V

**Output impedance:** 5 ohms or less

**Note:** When the Single Insert Phone option is used, it must be plugged into the left insert phone output.

**R6 - Bone Vibrator**

(1/4 inch phone jack)

Jack for bone vibrator or gray patch cord.

**Voltage:** 200  $\mu$ V to 5.00 V RMS

**Output impedance:** 5 ohms or less

**R7 - Subject Response Handswitch**

( 1/4 inch phone jack)

Accepts plug from the cable attached to the patient's response handswitch or handswitch patch cord.

Pin	Function	Voltage	Impedance
1	Shield	GND	0 ohm
2	Digital GND	GND	0 ohm
3	Response input	+5V/GND	1K ohm/0 ohm

**R8 - CD Player Power Jack**

(2 pin power jack)

Provides 5 V DC for CD Player.

**R9 - Dip Switch/Cal Switch**

An eight position bank of switches accessible by an authorized service representative.

**R10 - Speakers**

(5 pin Din connector) Located on rear of instrument.

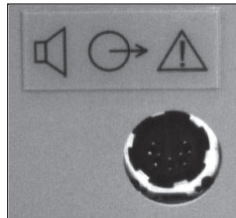

Connects to left and right loudspeakers.

Pin	Function	Impedance
1	Left speaker (high)	1.0 ohm
2	Left GND	0 ohm
3	Right speaker (high)	1.0 ohm
4	Left speaker (low)	1.0 ohm
5	Right speaker (low)	1.0 ohm
<b>SHLD</b>	Right GND	0 ohm

## Left Side Panel

The connectors on the left side panel are shown below.

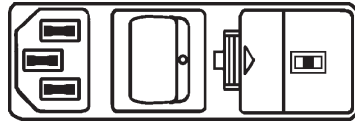

The power entry module is composed of the power switch, fuse drawer and voltage selection switch, and power cord with hospital grade plug appropriate for the country of destination.

When turned ON, the GSI 61 automatically initializes and displays a screen which states the type of audiometer (IEC and ANSI specified for speech audiometry) followed by a status screen. With the status display, the GSI 61 is brought to the initialization state.

The frequency is set at 1000 Hz and:

<b>Channel 1</b>	<b>Channel 2</b>
Steady tone	NB Noise
Phone-Right	Phone-Left
0 dB HL	-10 dB HL

## Right Side Panel

If you purchased an instrument with Remote and Printing capability, or purchased that option separately and have it installed, these connectors will be visible on the right side panel of the GSI 61.

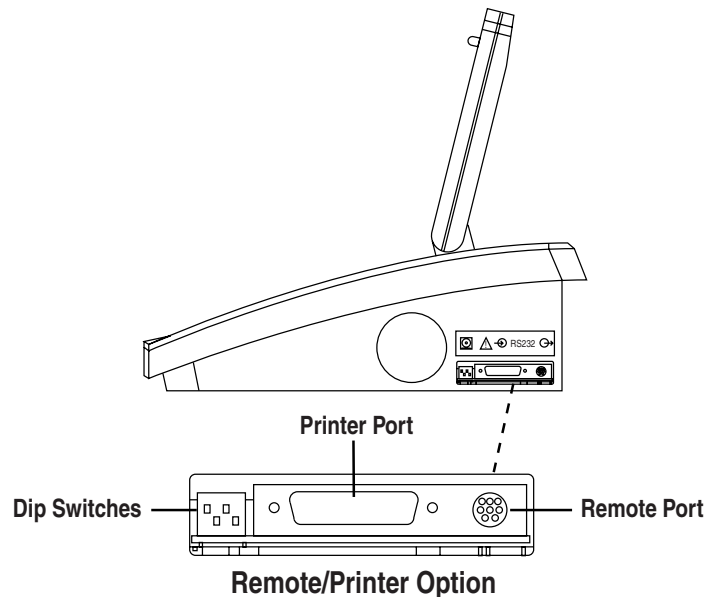

### RS 232 Remote Port

A mini-DIN connector uses a standard Apple “Hayes Modem” cable (supplied) to provide serial connection to your equipment.

### Printer Port

A 25-pin PC-Printer Interface Connector. Connects to your printer via a standard PC-parallel printer cable.

### DIP Switches

For more detail on these DIP switch settings, and attaching and using a printer, refer to the Optional Accessories section beginning on page 2-17.

## Front Panel Controls

The controls on the front panel of the GSI 61 are shown below.

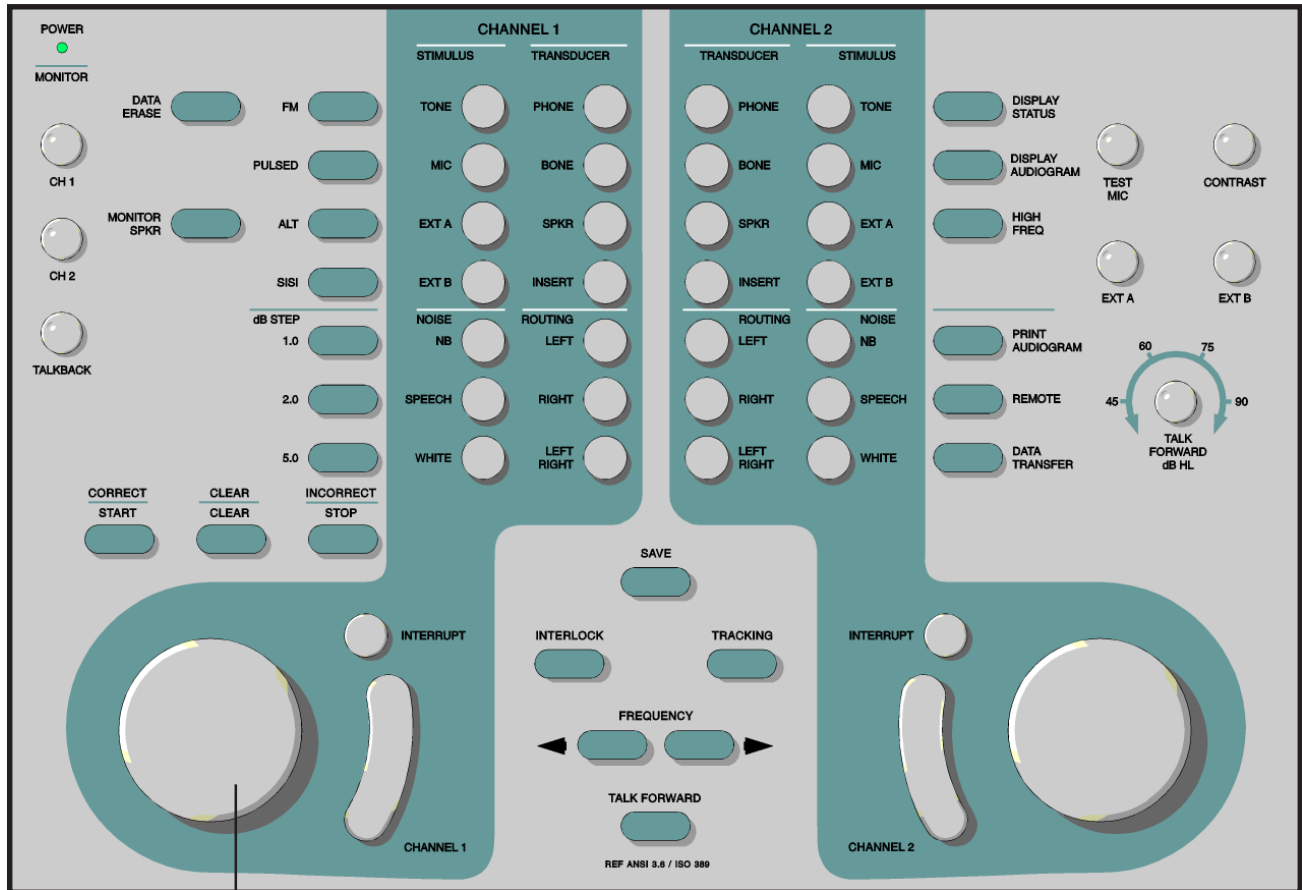

### Attenuators (HL Controls) Channel 1 and Channel 2

The GSI 61 contains two independent HL rotary controls for test signal and masking intensity level control with a range of -10 dB HL to 120 dB HL. (If the High Frequency option using Sennheiser earphones is installed and active, the High Frequency intensity level control ranges from -20 dB HL to 110 dB HL). Maximum dB HL values apply to the mid-frequencies with earphones only. Refer to the specific transducer for dB HL limits in the Table on page 2-23.

### dB Step Size

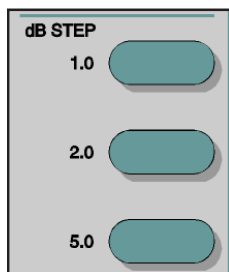

These pushbuttons allow the operator to change the intensity step size to 1.0, 2.0 or 5.0 dB. When the GSI 61 is powered up, the dB step size is automatically set to the default of 5 dB increments. These pushbuttons are also used to select the intensity increase when testing in the SISI mode.

**Signal Format Selectors** **FM - (Frequency Modulation or Warble Tone)**

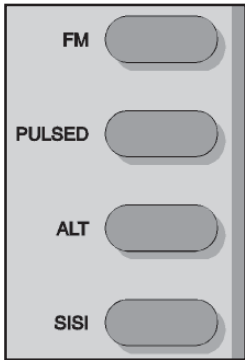

This pushbutton enables pure tones to be warbled at a rate of 5 Hz with a  $\pm 5\%$  allowable deviation around the selected center frequency. FM is available in all pure tone test modes, including SISI, Pulsed, ALT and High Frequency (optional).

**Pulsed** - This pushbutton causes the tone to be pulsed at the rate of 200 msec ON, 200 msec OFF. Note that the Pulsed tone is not available in SISI or ALTERNate test conditions. When a speech test mode is activated, Pulsed is no longer activated.

**Alternate** - This pushbutton locks both channels together and alternates the tone presentation between the two channels: 400 msec ON Channel 1, 400 msec OFF Channel 1, 400 msec ON Channel 2, 400 msec OFF Channel 2. Both channels receive TONE as the input stimulus. The frequency is automatically set to 1000 Hz and the dB step size, HL settings and the routing reflect the conditions prior to the selection of ALTERNate test type. The tones can be manually presented by depressing either PRESENT bar or automatically presented by pressing either INTERRUPT button. The intensity of the tones can be adjusted independently by use of the Channel 1 and Channel 2 attenuators.

**SISI** - This pushbutton provides an intensity increment every 5 seconds to a steady or FM tone in the selected channel for 200 milliseconds. The SISI test may be run at step sizes of 1.0, 2.0 or 5.0 dB. When SISI is selected, the GSI 61 automatically initializes Channel 1 to receive tone and Channel 2 to receive NB noise. The step size is initialized to 5.0 dB but may be changed to either 1.0 or 2.0 dB at any time during the test. Channel 1 and Channel 2 are set to 0 dB HL; the frequency is set to 1000 Hz. Output transducer and routing reflects the state of the GSI 61 prior to the selection of SISI. Depress the Interrupt pushbutton to allow the SISI increments to be presented every 5 seconds. Press the Interrupt button a second time to terminate the SISI presentation. (Operating the Channel 2 tone bar with Interlock selected in SISI also terminates the SISI increment presentation.)

In order to deselect the preselected signal format, change to any non-compatible test stimulus or push the same signal format again. The following table illustrates the compatibilities of test stimulus and signal formats.

**VALID SIGNAL FORMATS / STIMULUS COMBINATIONS**

	TONE	MIC	EXT A	EXT B	NBN	SPEECH	WHITE
FM	V	X	X	X	X	X	X
PULSED	V	X	X	X	V	X	V*
ALT	V	X	X	X	V	X	V*
SISI	V	X	X	X	X	X	X

V = Valid combination of signal format and stimulus.

X = Invalid combination of signal format and stimulus.

\* = When White/White is selected stimulus, calibration for White noise will be for speech.

## Stimulus Channel 1 and Channel 2

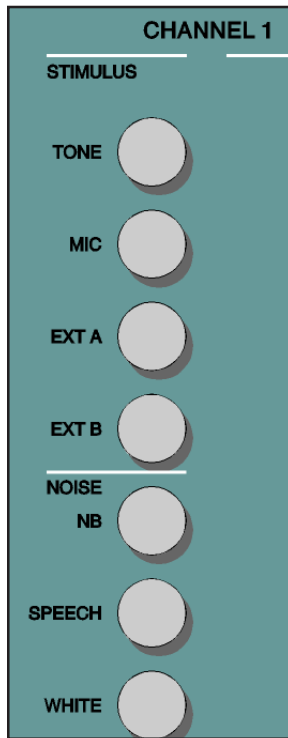

**Tone** — The Tone pushbutton allows the selection of a pure tone presentation for air/bone conduction testing with the choice of four transducer types; Phone (both the standard TDH 50P and the optional High Frequency earphones), Bone, Speaker, or Insert. When Tone is selected, Narrow Band Noise automatically routes to the opposite channel if the stimulus type on the opposite channel is not compatible with Tone. Note that the selection of Tone on one channel and Mic on the opposite channel is a valid combination. This setting allows the operator to have contact with the patient, especially a young child, without the need to select Talk Forward.

**Mic** — The Mic pushbutton provides input capability from the test microphone for live-voice testing with the choice of four transducer types: Phone, Bone, Speaker, or Insert. When Mic is selected, Speech Noise automatically routes to the opposite channel if the stimulus type on the opposite channel is not compatible with MIC. Note that the selection of Mic on one channel and Tone on the opposite channel is a valid combination. This setting allows the operator to have contact with the patient, especially a young child, without the need to select Talk Forward.

**Ext A, Ext B** — External A and External B accept recorded speech material from an optional compact disc player, a two channel tape cassette or a reel-to-reel tape recorder. When Ext A or Ext B is selected on one channel, Speech Noise automatically routes to the opposite channel if the stimulus type on the opposite channel is not compatible with Ext A or Ext B. Note that the selection of Ext A, or Ext B, on one channel and Tone on the opposite channel is a valid combination.

**Narrow Band Noise** — The NB Noise pushbutton selects narrow band noise. This is a noise centered at each test frequency and available for all frequencies with a 3 dB down bandwidth of greater than octave but less than ½ octave. The maximum dB HL is 15 dB below the maximum pure tone level and is calibrated in effective masking.

**Speech Noise** — The Speech Noise pushbutton selects speech noise. This is a white noise filtered to a low and middle frequency band, simulating the average spectrum of conversational speech. Speech noise is calibrated in effective masking level and consists of equal energy per frequency from 250 to 1000 Hz with a 12 dB/octave roll-off from 1000 to 6000 Hz. The maximum dB HL for speech noise is equal to the maximum HL for the speech type signals in each transducer.

**White Noise** — This pushbutton selects White Noise. White noise is a broad band signal containing acoustic energy at all frequencies between 125 Hz and 12000 Hz. White noise is calibrated for pure tone effective masking if a tone type signal is selected on the opposite channel, and for speech effective masking if a speech type signal is selected on the opposite channel. The maximum HL for white noise selected with a tone signal is 35 dB below the maximum pure tone level. The maximum HL for white noise selected with a speech signal is equal to the maximum HL for the speech signal.

Refer to the following table for the stimuli compatibilities listing.

**Valid Stimuli Combinations**

		Channel 1 Stimulus						
		Tone	Mic	Ext A	Ext B	NBNoise	S Noise	White Noise*
Channel 2 Stimulus	Tone	Valid	Valid	Valid	Valid	Valid	Invalid	Valid
	Mic	Valid	Valid	Valid	Valid	Invalid	Valid	Valid
	Ext A	Valid	Valid	Valid	Valid	Invalid	Valid	Valid
	Ext B	Valid	Valid	Valid	Valid	Invalid	Valid	Valid
	NBNoise	Valid	Invalid	Invalid	Invalid	Valid	Invalid	Invalid
	S Noise	Invalid	Valid	Valid	Valid	Invalid	Valid	Invalid
	W Noise*	Valid	Valid	Valid	Valid	Invalid	Invalid	Valid*

\* If White Noise is selected on both channels, then calibration is made to speech. If White Noise is selected on one channel only, calibration will be made to the stimulus type on the opposite channel.

**Transducer Output Selector**

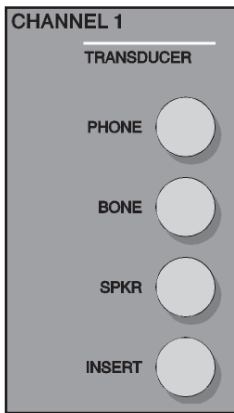

These pushbuttons allow the easy selection of the transducer for each stimulus available for Channel 1 and Channel 2. A transducer selection may be changed at any time.

**Valid Transducer Combinations**

		Channel 1			
		Phone	Bone	Speaker	Insert
Channel 2	Phone	Valid	Valid	Valid	Valid
	Bone	Valid	Valid	Valid	Valid
	Speaker	Valid	Valid	Valid	Valid
	Insert	Valid	Valid	Valid	Valid

**Routing Output Selector**

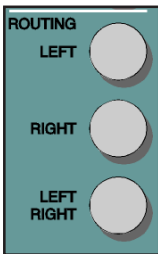

These pushbuttons allow the easy selection of the routing from the stimulus to the output transducer available for Channel 1 and Channel 2. When first powered on, the routing for Channel 1 will be right and the routing for Channel 2 is left. Left/Right mixes the stimuli from both channels to each transducer and drives both the left and right transducers with the combined signal. Both the Channel 1 and Channel 2 maximum dB HL limits in mixing are appropriately decreased from the non-mixed maximum dB HL limits. Left/Right -Left/Right routing is restricted to Phone/Phone, Speaker/Speaker and Insert/Insert (paired insert option). Left/Right routing is invalid for bone and the single insert phone.

**Tone Bar / Interrupt**

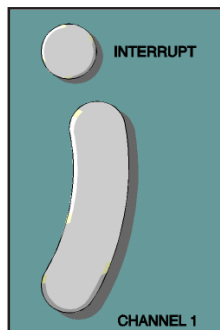

Each tone bar operates independently to cause the presentation of the selected stimulus for as long as the bar is depressed. The channel turns off immediately when the bar is released. When ALternate is selected and the tone bar is released, the complete presentation of both channel signals is completed. These pushbuttons determine the status of the respective tone bars and operate independently of each other. When the Interrupt is in the off position, the corresponding channel is activated by depressing the Tone bar and deactivated by releasing the Tone bar. To turn on the Interrupt, press the pushbutton. When Interrupt is in the on position, the corresponding channel is deactivated by pressing the Tone bar and activated by releasing the bar. When Interrupt is active, an icon is displayed on the LCD. Note that in the ALternate test mode, the Interrupt pushbuttons do not operate independently of each other.

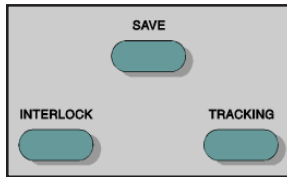
**Interlock**

This pushbutton locks both tone bars together so that operating one channel will also operate the other, according to the status of the Interrupt buttons. To unlock the Tone bars, press the Interlock button again. When the Interlock is active, a message is displayed on the LCD.

**Save**

This pushbutton, when pressed saves: the current dB HL level representing the threshold level, and effective masking level if selected, transducers and routing. In the Display Audiogram format, the appropriate symbol appears for each Save press.

**Tracking**

This pushbutton allows the Channel 2 hearing level to track the Channel 1 hearing level by a selected dB difference. When in Tracking, any dB change to the Channel 1 HL causes the Channel 2 HL to change by the same amount, until the limit of the Channel 1 transducer is reached. If the dB HL limit is reached in Channel 2 before Channel 1, the Channel 2 dB HL display will temporarily flash and remain at this level. Tracking remains on. When the Channel 1 dB returns to a level at which the selected difference between the two channels can resume, Channel 2 again tracks Channel 1. Tracking is in the off state upon initialization of any test type. Once tracking is selected, it is possible to manually change the intensity of Channel 2 to alter the dB difference between the two channels without deselecting Tracking. To exit Tracking, press the button again. When Tracking is active, a message is displayed on the LCD.

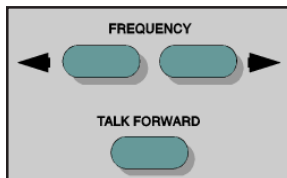
**Frequency Up/Down**

These pushbuttons allow the choice of twelve standard audiometric frequencies: 125 Hz, 250 Hz, 500 Hz, 750 Hz, 1000 Hz, 1500 Hz, 2000 Hz, 3000 Hz, 4000 Hz, 6000 Hz, 8000 Hz and 12000 Hz. If the high frequency option is activated, these pushbuttons allow a choice of nine high frequencies: 8 kHz, 9 kHz, 10 kHz, 11.2 kHz, 12.5 kHz, 14 kHz, 16 kHz, 18 kHz, and 20 kHz. Each press of the right (Ⓜ) pushbutton selects the next higher frequency. Each press of the left (Ⓜ) pushbutton selects the next lower frequency. The new frequency is selected when the pushbutton is released. When at the lower limit of the frequency selection, pressing the (Ⓜ) pushbutton will cause the display to roll over to the highest frequency limit, and vice versa. If a transducer with a narrower range is selected, only valid frequencies for that transducer are available.

See the Table entitled “dB HL Limits per Frequency and Transducer” in the Hearing Limits and Frequency Levels Section (pages 2-23 and 2-24) for the allowable frequency ranges of the specific transducers.

**Talk Forward**

Pressing this pushbutton allows the operator to speak directly to the patient through the microphone at the level set by the Talk Forward control by interrupting the stimulus presentation. Talk Forward can be used with any available transducer, including the optional High Frequency earphones. While Talk Forward is on, the only control which can be activated is the Print, if available. The GSI 61 resumes the test status held prior to pressing the Talk Forward pushbutton when the pushbutton is released.

**Scorer/Timer**

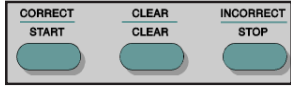

The Correct, Clear and Incorrect pushbuttons are used for scoring results in Speech, ALternate or SISI tests. The scorer is displayed in the test status area of the Status screen. When Speech, SISI or ALT is selected, the scorer initializes to 0/0 = 0%. The operator presses the Correct or Incorrect pushbutton after each presentation, depending on the response. The display indicates the number of correct responses and the total number of presentations along with the percentage of those correctly identified. The display clears with the pressing of the Clear pushbutton.

During tone tests (excluding ALternate and SISI), the Scorer/Timer pushbuttons may be used to start, clear and stop the timer. The timer is displayed in the test status area of the Status screen. When the timer is first selected, it initializes to 0:00 (0 minutes: 00 seconds). The timer starts when the Start pushbutton is pressed. Times up to 199 minutes and 59 seconds may be displayed before the timer resets to 0:00. The timer may be halted at any point by pressing the Stop pushbutton. The stopped time is displayed. Upon pressing the Start pushbutton after the Stop pushbutton, timing is resumed from the currently displayed value. Pressing Clear while the timer is running is invalid. Pressing Clear after Stop resets the timer to 0:00.

**Displays**

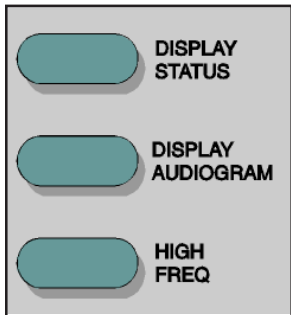

These pushbuttons are used to select the format for the screen display format on the LCD.

**Display Status** — When the Display Status pushbutton is pressed, the display is formatted as shown in the following Figure: Front Panel Display - Status. This display indicates the current instrument state and VU meters.

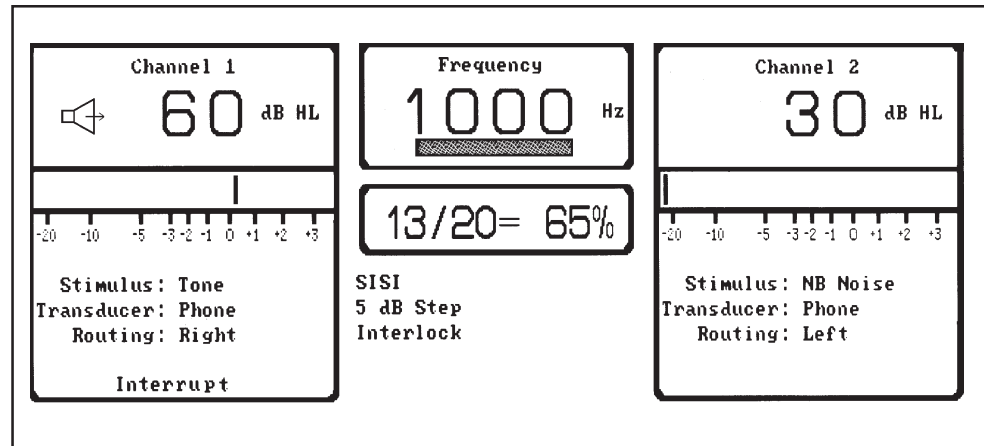

*Display Status*

**Display Audiogram** — When the Display Audiogram pushbutton is pressed, the display is formatted as shown in the following Figure: Front Panel Display - Audiogram. Two audiograms with the standard range of frequencies (125 Hz to 12,000 Hz), or the High Frequency ranges (8 kHz to 20 kHz), and the instrument status are displayed. Hold the **Display Status** key for 2.5 seconds to view the left audiogram on the left side, and right on the right side. Hold the **Display Status** key again to reverse back to the original setting..

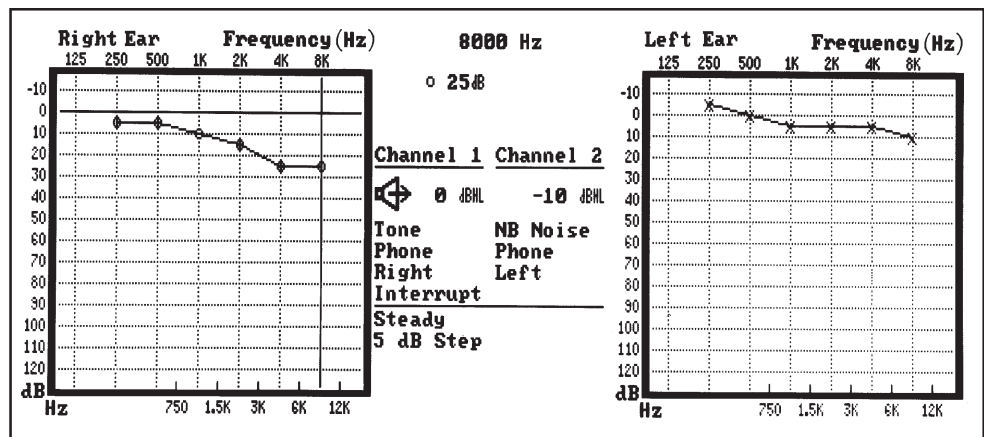

Display Audiogram

**High Frequency** — When the High Frequency pushbutton is pressed with the High Frequency option installed, the system allows tone testing in the extended range from 8 kHz to 20 kHz. The display remains in the Display Status or Display Audiogram format as previously selected. If the High Frequency option has not been installed and the pushbutton is pressed, the error message “Not Available” appears in the error message area of the display.

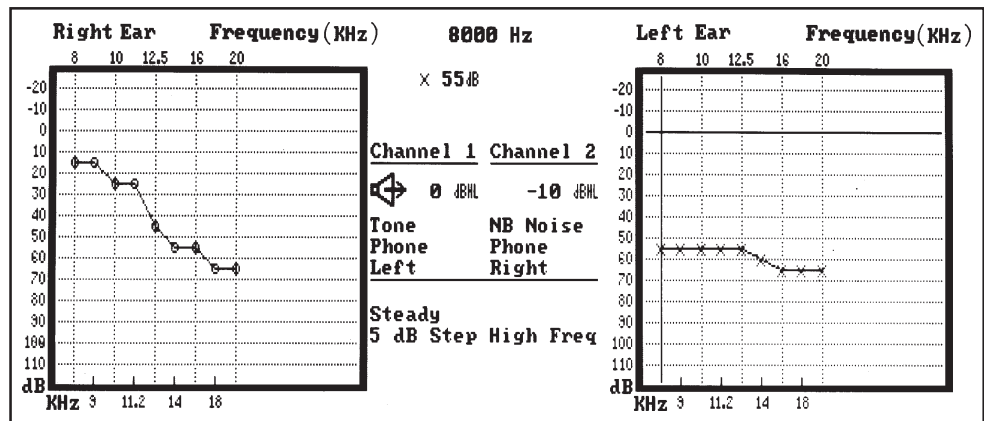

Display High Frequency

**Print Audiogram**

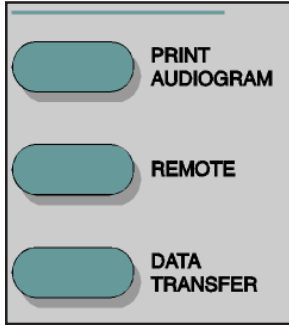

If the printer option is available and the Print Audiogram pushbutton is pressed, the current saved test information in audiogram format is sent to the printer. If there is no data stored in the GSI 61 memory and the Print Audiogram pushbutton is pressed, the message “No Test Data Stored” appears in the error message area. If the printer option is not active and the pushbutton is pressed, the message “Not Available” appears.

**Remote**

When the Remote (RS232) option is installed, pressing the Remote pushbutton allows the GSI 61, when connected to an external computer, to transmit and receive data from this device. If the option is not installed and the pushbutton is pressed, the message “Not Available” appears.

**Data Transfer**

When Remote is enabled and the Data Transfer button is pressed, a data record containing the stored test data in a previously selected format is transmitted to a remote device. Data may be transferred point-by-point or as a complete battery of all saved test results. The data transfer format is set by an authorized GSI Service Engineer. If the pushbutton is pressed when the Remote option is not active, the message “Not Available” is displayed.

**Data Erase**

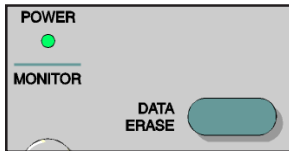

When the Data Erase pushbutton is pressed for at least 0.5 second, all of the stored test data in the GSI 61 is erased and the message “Erasing Data” is displayed on the LCD. If no data is stored in the GSI 61 memory, the message “No Test Data Stored” is displayed.

**Contrast**

This rotary control is used to set the brightness of the LCD.

**Mic, Ext A and Ext B Level Controls**

These rotary controls are used to adjust the signal intensity from the test microphone or the external devices, so that the level reflects accurately on the VU meters on the Status display. These inputs are adjusted by turning the appropriate control until an indication of 0 dB on the average is obtained on the selected channel VU meter. Note: it has been suggested that for live voice speech testing, the operator should calibrate the GSI 61 to a 1000 Hz pure tone introduced into the microphone. When using an external source, calibrate to the 1000 Hz pretest tone.



**Talk Forward Level Control**

This rotary control allows the operator to adjust the intensity in a continuous range of 45 to 90 dB HL when giving the subject instructions through use of the Talk Forward function. The level selected by this control is calibrated to the transducer currently being used with the subject.

## Monitor Controls

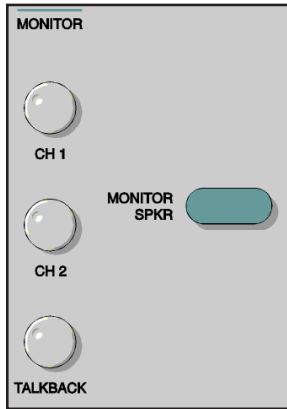

The Monitor Headphone or Speaker allows the operator to listen to the stimuli as they are presented or to listen to the patient's comments through the talk-back system. The **Channel 1** and **Channel 2** rotary controls adjust the intensity of the sound presented through the monitor headphone or speaker. The **Talkback** rotary control adjusts the intensity of the patient's voice. The **Monitor Spkr** pushbutton is used to turn on the Monitor Speaker. When Mic is selected, or when the Talk Forward is operated, that channel's input to the monitor speaker is disabled to reduce acoustic feedback.

## Power



This Power Monitor green light emitting diode (LED), located in the upper left portion of the keypanel, is illuminated when power is supplied to the GSI 61.

## Displays

A Liquid Crystal Display (LCD) is hinged to the GSI 61 and is used to display all of the testing information from the instrument. When the LCD is in the lowered position, easy access to the rear connector panel is provided.

The data from the GSI 61 is provided in two formats, Instrument Status and Audiogram. The following figure shows the Instrument Status screen.

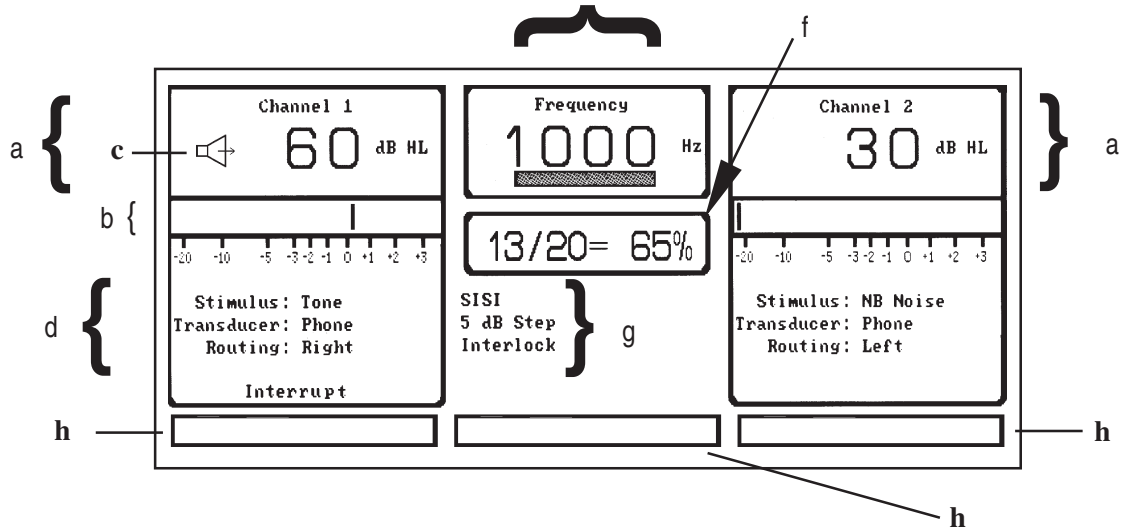

- a. The output, in dB HL, for Channel 1 and Channel 2.
- b. A graphical representation of the VU meters for each channel.
- c. The tone ON icon which is displayed when the presentation is made.
- d. The stimulus, transducer and routing currently selected for each channel.  
If the Interrupt is on, this is also displayed in this area.
- e. Frequency, in Hz, selected for Channel 1 or Channel 2.  
The indicator bar for the subject response displays when the handswitch is depressed.  
When a speech type condition is selected, this area is blank.
- f. Timer/Scorer.
- g. General system state, including tone presentation format, dB step size, special tests, monitor speaker, High Frequency (optional), Remote (optional) with data transfer, and print (optional).
- h. Error messages/status messages. Refer to Chapter 7 for a description of the error and status messages. These boxes appear only when a message is displayed.

The following figure is a representation of the standard audiogram.

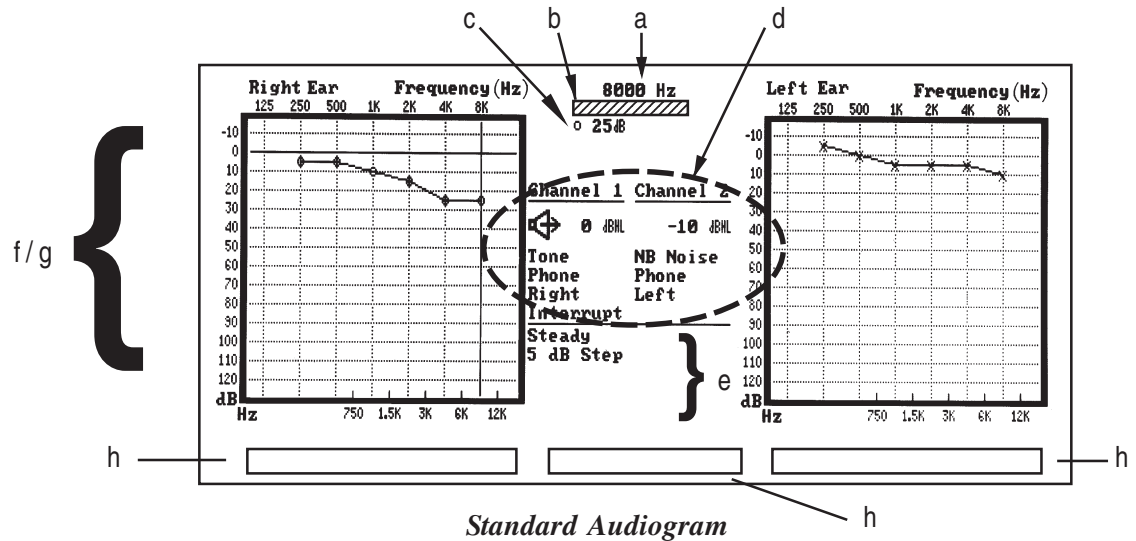

- a. Frequency, in Hz, selected for Channel 1 or Channel 2.
- b. The indicator bar for the subject response displays when the handswitch is pressed.
- c. The saved dB HL (and effective masking level) for the intersected frequency and Hearing Level.
- d. Current output in dB HL for Channel 1 and Channel 2; also the stimulus, transducer and routing currently selected for each channel. If the Interrupt is on, this is also displayed in this area. The tone ON icon is displayed when the presentation is made.
- e. The general system state, including signal format, dB step size, special tests, monitor speaker, High Frequency (optional), Remote (optional) with data transfer, and print (optional).
- f. The graphical representation of the audiogram. The display is designed so that the patient's right ear audiogram will be on the operator's left portion of the display. The left ear is on the right side of the display. In the above figure, the x axis is labeled *Left Ear* or *Right Ear Frequency (Hz)* and is marked at the octave intervals of: 125 Hz, 250 Hz, 500 Hz, 1 kHz, 2 kHz, 4 kHz and 8 kHz. The dashed grid lines are displayed at the one-half octave intervals of: 750 Hz, 1.5 kHz, 3 kHz, 6 kHz, and 12 kHz. The y axis is Hearing Level in dB HL. This ordinate is incremented every 10 dB, starting at -10 dB and ending at 120 dB.
- g. When a result is saved, the appropriate audiometric symbol is located on the audiogram. No Response symbols are placed on the audiogram at the maximum output limit for the transducer and frequency combination.
- h. Error message/status message. Refer to Chapter 7 for a description of the error and status messages. These boxes appear only when a message is displayed.

In the next figure, High Frequency Audiogram, the x axis is labeled *Right Ear* or *Left Ear Frequency (kHz)* and is marked at the frequency levels of 8 kHz, 10 kHz, 12.5 kHz, 16 kHz, and 20 kHz. The dashed grid lines are displayed at the intermediate frequencies of 9 kHz, 11.2 kHz, 14 kHz and 18 kHz. The y axis ordinate is incremented every 10 dB, starting at -20 dB HL and ending at 110 dB HL. A crosshair, spanning the length and width of the audiogram, shows the current frequency and dB level for the ear under test.

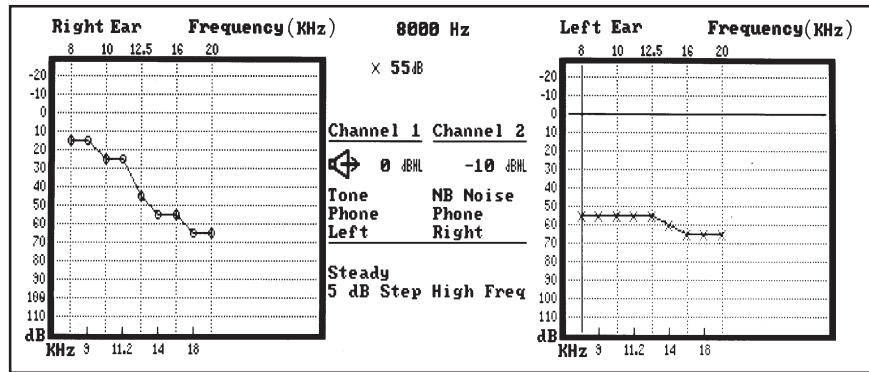

*High Frequency Audiogram*

## Audiometric Symbols

	<u>Response</u>	<u>No Response</u>	<u>Description</u>
Left Ear	×	×	Air conduction, unmasked, phone or insert
	□	□	Air conduction, masked, phone or insert
	>	↘	Bone conduction, Mastoid, unmasked
	]	]	Bone conduction, Mastoid, masked
	┌	┌	Bone conduction, Forehead, Masked
Right Ear	○	○	Air conduction, unmasked, phone or insert
	△	△	Air conduction, masked, phone or insert
	<	↘	Bone conduction, Mastoid, unmasked
	]	]	Bone conduction, Mastoid, masked
	┌	┌	Bone conduction, Forehead, masked
Non-ear Specific	∨	∨	Bone Conduction, Forehead, unmasked
	⊞	⊞	Sound Field, aided or unaided

## Test Microphone/Monitor Headset

The selection of any stimulus will deselect a previously selected stimulus on the opposite channel if the stimuli are not compatible.

The lightweight test microphone/monitor headset supplied with the GSI 61 provides the operator complete comfort and utility.

A standard microphone is positioned at the end of the adjustable boom. The microphone boom rotates 225 degrees so that the microphone may be worn on either the right or left side of the head.

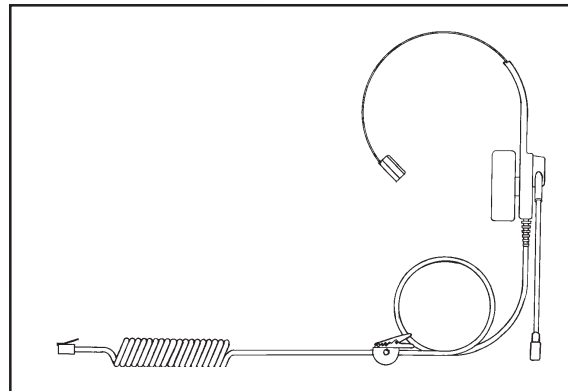

Place the headset on your head by spreading the headband slightly. Then locate the receiver directly on the ear and slide the headband to adjust the fit. The microphone must be positioned close to the tester's mouth so that the filter is almost in contact with the lower lip. The white dot on the base of the microphone must face the tester's mouth.

The GSI 61 permits the operator to speak through the test microphone into the test transducer at continuously variable intensities from 45 dB HL to 90 dB HL in the Talk Forward mode. The tester's lips maintain a constant distance from the microphone enabling the VU meter to uniformly average at 0 dB for live voice testing.

A lapel clip and a 10 foot coiled cord with a quick disconnect are included. The telephone jack connector attaches the test microphone/monitor headset to the rear panel.

There are two insert earphone options available for use with the GSI 61. The first

## Optional Accessories

### E•A•RTONE™ Insert Earphone Set



option is the paired E•A•RTONE™ Insert Earphone Set which allows for the use of these insert phones in addition to the TDH 50P earphones. The phones are connected to the panel on the rear of the GSI 61 in the positions labeled Insert Left and Insert Right.

The use of these insert earphones is recommended in order to minimize collapsing of the ear canals while reducing the occlusion effect seen in bone conduction testing when the ear is covered. Insert phones are ideal for hearing aid evaluations where they can be used to accurately simulate situations for speech testing of hearing aided patients. Noise exclusion is improved at low frequencies where background noise may be a problem. These insert phones may be used with tone (125 Hz to 8000 Hz), speech and noise signals.

### Single Insert Phone

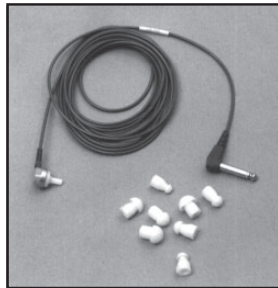

The second insert phone option is a single phone. This insert may be used with tone (250 Hz to 6000 Hz), speech and noise signals.

**Note:** When the single insert option is used, the insert phone is connected to the rear of the GSI 61 at the Insert Left position.

### Printer

An optional color or black-and-white printer may be attached to the GSI61 to allow printing of the audiometric test results. *You may also purchase this option factory installed on the GSI 61.* In addition to a choice of color or black-and-white, a choice of separate left and right or overlaid left and right audiograms is provided.

The GSI 61 supports most HP (Hewlett Packard) DeskJet Series Printers that use PCL-3. Contact GSI Service for specific models..

The Remote/Printer board option includes a set of external DIP switches which enable the operator to reconfigure the printer color and the audiogram format. The board is located on the right side, near the rear of the instrument. Refer to the figure on page 2-4. The switch definitions are as follows:

**DIP Switches****Audiogram Format**

<i>Dip switch 1</i>	<i>Selection</i>
OFF	Separate Left and Right Audiograms
ON	Overlaid Left and Right Audiograms

**Printer Color**

<i>Dip switch 2</i>	<i>Selection</i>
OFF	Color Printing
ON	Black and white Printing
Dip switch 3	Not Used.

**Print Bar Code**

<i>Dip switch 4</i>	<i>Selection</i>
OFF	Do not print bar code
ON	Print bar code

**Parallel Port**

The Remote/Printer board has a standard “PC-type” parallel printer port. The printer is connected to this port with a standard “PC-type” parallel printer cable.

**User Interface**

**Printing** Pressing the **PRINT AUDIOGRAM** pushbutton on the front panel of the GSI 61 will send the stored threshold data to the printer. If turn ON, a bar code will be printed with the audiogram. The bar code can be used to quickly input data with AudioScan systems.

**Cancel the Print** Printing may be cancelled by pressing the **PRINT AUDIOGRAM** pushbutton a second time while the “Printing” message is displayed. A “Printing Cancelled” message will then flash on the display.

**Multiple Copies** Additional copies of the audiometric test results are printed each time the **PRINT AUDIOGRAM** pushbutton is pressed, after the “Printing” message disappears from the display.

**Instrument Operation while Printing**

The GSI 61 remains operational while printing with the following exceptions: pressing the **Data Erase**, **Save**, **Data Transfer** and **Remote** pushbuttons will result in the error message “**Invalid Selection**”.

**Remote Operation/RS 232 Interface**

The Remote port operation is **inactive** while audiometric test results are being printed.

## Error Messages

The GSI 61 displays error messages when the **PRINT AUDIOGRAM** pushbutton is pressed when the following conditions exist:

If there is currently no saved data, this error message will be flashed:  
**No Test Data Stored**

If test data exists, the presence of the Remote/Printer Option board is verified; if it is not present, this error message will be flashed:  
**Not Available**

If the Remote/Printer Option board is present, a check will be done to see if a print job is already in progress. If so, it will be cancelled as described earlier. If the Remote is currently in use, this error message will be flashed:

**Invalid Selection**

If all of the above is satisfied, a check is done to see if the printer is connected and ready to receive data. If not, this error message will be flashed:

**Check Printer**

When all of the above is satisfied, an informational message is displayed while outputting data to the printer:

**Printing**

If, during the course of printing, communications problems occur, this error message will be flashed:

**No Printer Response**

Printer Output Formats The printout formats are shown in the following four figures.

Name: \_\_\_\_\_ ID #: \_\_\_\_\_  
 Age: \_\_\_\_\_ Sex: F M Date: \_\_\_\_\_ Time: \_\_\_\_\_  
 I 61 Audiometer S/N: \_\_\_\_\_ Tester: \_\_\_\_\_ Reliability: \_\_\_\_\_

**Right Ear** Frequency (Hz) **Audiogram Symbol Key** **Left Ear** Frequency (Hz)  
 125 250 500 1K 2K 4K 8K 125 250 500 1K 2K 4K 8K  
 -10 0 10 20 30 40 50 60 70 80 90 100 110 120  
 750 1.5K 3K 6K 12K 750 1.5K 3K 6K 12K

AC Unmasked  $\circ$  X  
 AC Masked  $\Delta$   $\square$   
 BC Unmasked  $\triangleleft$   $\triangleright$   
 BC Masked  $\square$   $\square$   
 Forward Masked  $\uparrow$   $\downarrow$   
 BOTH BC Forward Unmasked  $\downarrow$   
 Sound Field  $\$$   $\$$   
 Example of NR  $\circ$   $\Delta$   $\triangleleft$   $\triangleright$   $\square$   $\square$   $\uparrow$   $\downarrow$   $\$$   $\$$

Effective Masking Levels To Non-Test Ear  
 AC \_\_\_\_\_ BC \_\_\_\_\_

Speech Audiometry					
	PTA	MCL	UCL	SRT	Speech Discrimination
GHT					
FT					
				CD <input type="checkbox"/>	Tape <input type="checkbox"/> MLV <input type="checkbox"/>

Comments: \_\_\_\_\_

Low Frequency Dual Audiogram Format

Name: \_\_\_\_\_ ID #: \_\_\_\_\_  
 Age: \_\_\_\_\_ Sex: F M Date: \_\_\_\_\_ Time: \_\_\_\_\_  
 GSI 61 Audiometer S/N: \_\_\_\_\_ Tester: \_\_\_\_\_ Reliability: \_\_\_\_\_

**Right / Left** Frequency (Hz) **Audiogram Symbol Key**  
 125 250 500 1K 2K 4K 8K 125 250 500 1K 2K 4K 8K  
 -10 0 10 20 30 40 50 60 70 80 90 100 110 120  
 750 1.5K 3K 6K 12K 750 1.5K 3K 6K 12K

AC Unmasked  $\circ$  X  
 AC Masked  $\Delta$   $\square$   
 BC Unmasked  $\triangleleft$   $\triangleright$   
 BC Masked  $\square$   $\square$   
 Forward Masked  $\uparrow$   $\downarrow$   
 BOTH BC Forward Unmasked  $\downarrow$   
 Sound Field  $\$$   $\$$   
 Example of NR  $\circ$   $\Delta$   $\triangleleft$   $\triangleright$   $\square$   $\square$   $\uparrow$   $\downarrow$   $\$$   $\$$

Effective Masking Levels To Non-Test Ear  
 AC L \_\_\_\_\_ A \_\_\_\_\_  
 BC L \_\_\_\_\_ h \_\_\_\_\_

Speech Audiometry					
	PTA	MCL	UCL	SRT	Speech Discrimination
RIGHT					
LEFT					
				CD <input type="checkbox"/>	Tape <input type="checkbox"/> MLV <input type="checkbox"/>

Comments: \_\_\_\_\_

Low Frequency Combined Audiogram Format

me: _____		ID #: _____	
Age: _____	Sex: F M	Date: _____	Time: _____
SI 61 Audiometer	S/N: _____	Tester: _____	Reliability: _____

<p><b>Right Ear</b>      Frequency (KHz)</p>	<p><b>Audiogram Symbol Key</b></p> <p>right left</p> <p>AC unmasked ○ ×</p> <p>AC masked △ □</p> <p>Sound Field § †</p> <p>Example of NR</p>	<p><b>Left Ear</b>      Frequency (KHz)</p>
--	--	---

<p>Effective Masking Levels To Non-Test Ear</p> <p>AC <table border="1" style="display: inline-table; border-collapse: collapse;"><tr><td style="width: 15px; height: 15px;"></td><td style="width: 15px; height: 15px;"></td><td style="width: 15px; height: 15px;"></td><td style="width: 15px; height: 15px;"></td><td style="width: 15px; height: 15px;"></td></tr></table></p>						<p>Effective Masking Levels To Non-Test Ear</p> <p>AC <table border="1" style="display: inline-table; border-collapse: collapse;"><tr><td style="width: 15px; height: 15px;"></td><td style="width: 15px; height: 15px;"></td><td style="width: 15px; height: 15px;"></td><td style="width: 15px; height: 15px;"></td><td style="width: 15px; height: 15px;"></td></tr></table></p>					

Comments: \_\_\_\_\_

\_\_\_\_\_

\_\_\_\_\_

\_\_\_\_\_

\_\_\_\_\_

\_\_\_\_\_

\_\_\_\_\_

\_\_\_\_\_

\_\_\_\_\_

\_\_\_\_\_

**High Frequency Dual Audiogram Format**

me: _____		ID #: _____	
Age: _____	Sex: F M	Date: _____	Time: _____
SI 61 Audiometer	S/N: _____	Tester: _____	Reliability: _____

<p><b>Right / Left</b>      Frequency (KHz)</p>	<p><b>Audiogram Symbol Key</b></p> <p>right left</p> <p>AC unmasked ○ ×</p> <p>AC masked △ □</p> <p>Sound Field § †</p> <p>Example of NR</p>	<p>Effective Masking Levels To Non-Test Ear</p> <p>AC <table border="1" style="display: inline-table; border-collapse: collapse;"><tr><td style="width: 15px; height: 15px;"></td><td style="width: 15px; height: 15px;"></td><td style="width: 15px; height: 15px;"></td><td style="width: 15px; height: 15px;"></td><td style="width: 15px; height: 15px;"></td></tr></table></p>					

Comments: \_\_\_\_\_

\_\_\_\_\_

\_\_\_\_\_

\_\_\_\_\_

\_\_\_\_\_

\_\_\_\_\_

\_\_\_\_\_

\_\_\_\_\_

\_\_\_\_\_

\_\_\_\_\_

**High Frequency Combined Audiogram Format**

## High Frequency



The option exists to include high frequency audiometry on the GSI 61. The High Frequency earphones are connected to stereo cable extensions which in turn are connected into the Right and Left phone jacks on the rear panel. When the High Frequency option is installed, connect the standard TDH 50P earphone cords into the stereo cable extensions labeled Std. The following two figures show the installation of the High Frequency and THD 50P earphones. When the Sennheiser High Frequency phones are used and the High Frequency option is enabled, the frequencies available for testing are 8 kHz, 9 kHz, 10 kHz, 11.2 kHz, 12.5 kHz, 14 kHz, 16 kHz, 18 kHz and 20 kHz. The intensity range is

from -20 dB to 110 dB HL. High Frequency audiometry can also be performed in Sound Field using the Basic Speakers configuration. In High Frequency Sound Field, the frequencies of 8 kHz, 9 kHz, 10 kHz, 11.2 kHz, 12.5 kHz, 14 kHz, 16 kHz are available.

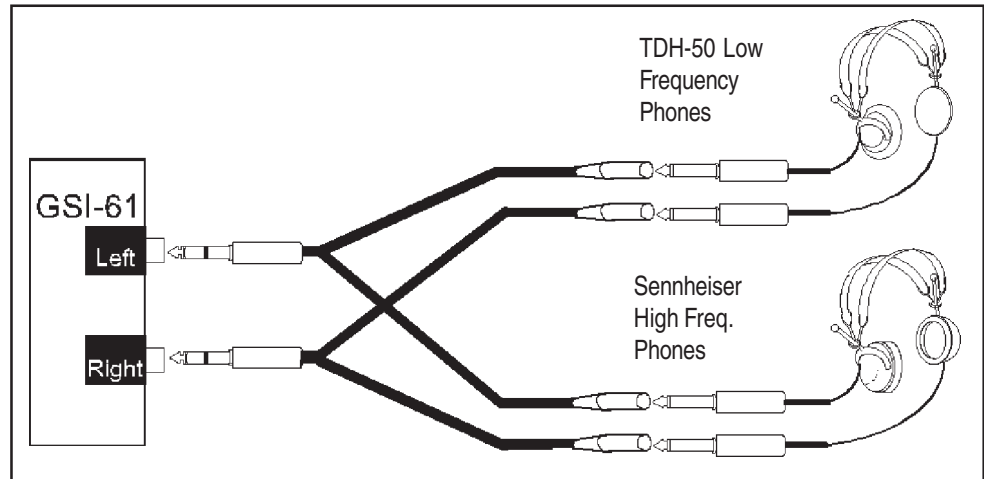

*High Frequency Option Setup: No Sound Booth*

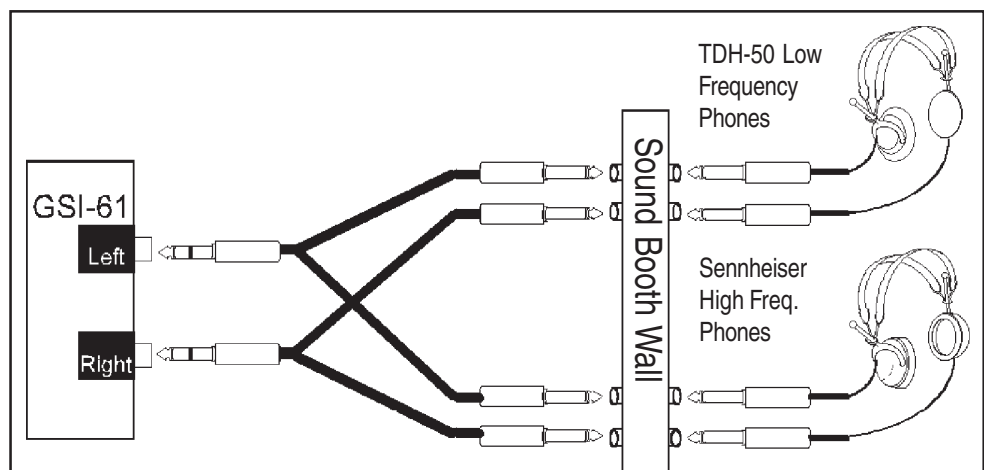

*High Frequency Option Setup: With Sound Booth*

## Hearing Level And Frequency Limits

### Hearing Level (dB HL)

It is not possible to select a dB HL value outside the limits for a particular transducer/frequency combination. An attempt to change or select a hearing level control that is outside of the limit will result in the following:

1. The dB HL will stop at the limit value, or
2. The dB HL will go to the nearest allowable level.

In either case, the dB HL display will flash momentarily and then the test channel value will be replaced with NR (No Response). If an audiogram is displayed and the limits for a frequency/transducer are reached, the symbol for no response is displayed in the audiogram. When Speaker is selected on both channels and the optional booster amplifier is not installed, it is possible to increase Channel 2 to a higher hearing level if Channel 1 is lowered. For example, select SPKR/SPKR, 1000 Hz, Tone/Narrow Band, and Left for Channel 1 and Right for Channel 2. Set both Channel 1 and Channel 2 at the maximum dB HL levels. If Channel 1 is lowered by 5 dB, it is possible to then increase Channel 2 by 5 dB.

### Frequency Limits

It is not possible to select a test frequency that is invalid for a particular transducer. The Test Frequency buttons will roll over to the lowest frequency after the last valid frequency or the frequency will automatically go to the nearest valid value when a different transducer is selected.

### dB HL Limits per Frequency and Transducer

Test Signal, Pure Tone	Ear Phone	Bone Vibrator-Mastoid	Bone Vibrator-Forehead	E A R Tone 3A Insert Phone	Single Insert Phone	1761-9630 Sound Field 45° Azimuth	1761-9635 Sound Field 45° Azimuth	1761-9639 Sound Field 45° Azimuth	High Frequency Ear Phone <sup>1</sup>
125	85	N/A	N/A	90	N/A	70	70	75	
250	105	45	33	100	100	65	75	90	
500	120	65	51	110	110	95	100	110	
750	120	70	57	115	110	100	105	110	
1000	120	75	66	115	110	100	105	110	
1500	120	80	69	115	110	100	105	110	
2000	120	80	68	115	110	100	105	115	
3000	120	80	68	115	110	105	105	115	
4000	120	75	67	115	105	105	105	115	
6000	110	50	39	105	90	95	95	105	
8000	100	45	35	90	N/A	80	80	85	100
12000	75	N/A	N/A	N/A	N/A	80	60	75	
Speech	105 <sup>2</sup>	65	56	110	95	90	96	102	

## dB HL Limits per Frequency and Transducer continued

Test Signal, Pure Tone	Ear Phone	Bone Vibrator-Mastoid	Bone Vibrator-Forehead	E A R Tone 3A Insert Phone	Single Insert Phone	1761-9630 Sound Field 45° Azimuth	1761-9635 Sound Field 45° Azimuth	1761-9639 Sound Field 45° Azimuth	High Frequency Ear Phone <sup>1</sup>
Speech Noise	105 <sup>2</sup>	65	55	105	95	80	96	92	N/A
9000						80	N/A	N/A	100
10000						80	N/A	N/A	95
11200						80	N/A	N/A	95
12500						80	N/A	N/A	84
14000						75	N/A	N/A	75
16000						50	N/A	N/A	55
18000						N/A	N/A	N/A	33
20000						N/A	N/A	N/A	14

**Notes:**

1. The High Frequency Phones specified are the Sennheiser HDA 200 Phones.
2. The maximum hearing level for speech with the speech filter in place is 100 dB.

**Note:** The hearing levels listed in this table are guaranteed maximum levels. These levels are guaranteed only if ANSI, ISO or GSI reference threshold levels, and not customized calibration values, are used. The GSI 61 provides hearing level limits to at least the values listed. However, at no time will the hearing level limit exceed 120 dB HL.

## Initial Installation

### Elimination of Ambient Noise

The GSI 61 can be installed in a single room environment or as part of a two room suite.

Excessive noise in the test environment, such as that produced by conversation, typewriters, printers, or other machines reduces test validity because it tends to mask the test signals, particularly at the lower frequencies where earphone cushions provide less effective attenuation. A room that attenuates sound may be required if ambient noise at the patient’s ears reaches levels sufficient to cause apparent hearing loss at the lower frequencies.

Maximum permissible test environment sound-pressure levels are specified by American National Standard Criteria for Permissible Background Noise during Audiometric Testing, Section 3.1. The following table shows the maximum background levels that can be present inside the room while a valid hearing test is being conducted. These values apply for hearing threshold measurements to 0 dB HL.

**Maximum Ambient Noise**

Test Tone Freq. (Hz)	125	250	500	750	1000	1500	2000	3000	4000	6000	8000
Test Room level max dB SPL, ears covered	29.0	17.5	14.5	16.5	21.5	21.5	23.0	28.5	29.5	33.0	38.5
Max level dB SPL, ears not covered	23.0	13.5	9.5	7.5	9.0	5.5	3.5	3.5	4.0	9.0	15.5

**Notes:**

Maximum permissible 1/3 octave band level

If the Hearing Level to be measured is -10 dB HL, then 10 dB should be subtracted from the levels listed in this table.

**Note:** A room providing sound isolation from ambient noise is highly recommended so that hearing threshold values may be obtained. If a separate examination (sound) room is used, it is considered sufficiently quiet for the purposes of these tests if a group of otologically “normal” listeners with their ears occluded is unable to detect any ambient noise during the test period. See ANSI S3.1 Criteria for Permissible Ambient Noise during Audiometric Testing for maximum allowable outside octave band noise levels with three prefabricated sound room types.

**Note:** Live voice testing requires a separate sound attenuated room for the patient in order to avoid feedback and direct transmission of the test stimuli.

## Single Room Environment

Place the GSI 61 on the desk or table where it will subsequently be used. The location should be near a grounded electrical outlet which is needed to accommodate the GSI 61 power cord. Allow a minimum of 2 inches of clearance around the GSI 61 for heat dissipation.

- a. Refer to Rear Panel Figure, page 2-2. With the LCD panel in the down position to allow access to the rear connector panel, connect the following.
  - Test microphone/ monitor headset
  - External A and External B (if used)
  - Power cord for the CD player (if used)
  - Patient talk back microphone
  - Test headset - red right ear phone, blue left ear phone or the cables for the optional High Frequency phones
  - Insert ear phones (optional)
  - Bone vibrator
  - Patient response handswitch
  - Speakers
  - Printer
- b. To connect the optional high frequency earphones, see the figures on page 2-22.
- c. Plug the power cord into an active outlet.
- d. Turn the unit on and observe that the GSI 61 is receiving power. (The small Monitor Power LED on the front panel is illuminated). The unit is initialized to Tone, Phone, Right, 0 dB HL, 1000 Hz Channel 1; and Narrow Band Noise, Phone, Left, -10 dB HL, Channel 2.
- e. Test all of the input and output transducers that are to be used during testing to verify that the signals and communication functions are operating properly.

## Two Room Installation

Place the GSI 61 on the desk or table where it will subsequently be used. The location should be near a grounded electrical outlet which is needed to accommodate the GSI 61 power cord. Allow a minimum of 2 inches of clearance around the GSI 61 for heat dissipation.

- a. Connect the patient response handswitch, the headset, bone vibrator, and optional insert phone(s) to the connector panel on the inside of the sound room.
- b. Mount the Talkback microphone in the sound room using the hardware provided. The microphone is usually mounted just above the window frame. Pass the microphone plug through the grommet hole in the jack panel and connect directly to the talk back microphone jack on the GSI 61 rear panel (R3).

**Do not use a patch cord with the Talkback microphone as interference can occur.**

- c. Use the supplied patch cords to connect the GSI 61 output jacks for all transducers to the corresponding points in the connector panel on the outside of the examination (sound) room. Refer to the Figures on page 2-22 for the optional High Frequency installation. Plug the monitor headset into the rear panel jack.

**Be certain that the transducers connect to the corresponding patch cords through the connector panel.**

- d. Connect the optional speaker cable to the connector marked Speaker on the rear of the GSI 61. Pass the other ends of the cable through the grommet holes in the control panel of the sound room. Connect the cable marked “left” to the left speaker, and the one marked “right” to the right speaker.

**CAUTION: The wire ends must not touch each other or any other conductive surface! Do not use patch cords with or instead of the supplied speaker cables. Damage to amplifiers inside the GSI 61 will occur.**

- e. Mount the speakers in the corners of the sound room. Position the speakers three feet (one meter) from the patient. The cone of the speaker should be at the same height as the ear of the average patient seated in the normal listening position. Note: All transducers are pre-calibrated except for the speakers. Contact your local GSI representative to install and calibrate your sound field system within your facility.
- f. Plug the power cord into a grounded outlet.
- g. Turn the unit on and observe that the GSI 61 is receiving power. (The small power LED on the front panel is illuminated). The unit is initialized to Tone, Phone, Right, 0 dB HL, 1000 Hz Channel 1; and Narrow Band Noise, Phone, Left, -10 dB HL, Channel 2.
- h. Test all of the input and output transducers to verify that the signals and communication functions are operating properly.

## Loudspeaker Installation

The installation of the Basic Speakers, 1761-9630, with the GSI 61 provides a guaranteed maximum level in speech of 90 dB HL (with a 6 ft x 6 ft room, and the patient seated one meter from the speakers).

**Note that the High Frequency with Sound Field can only be selected with the Basic Speakers.**

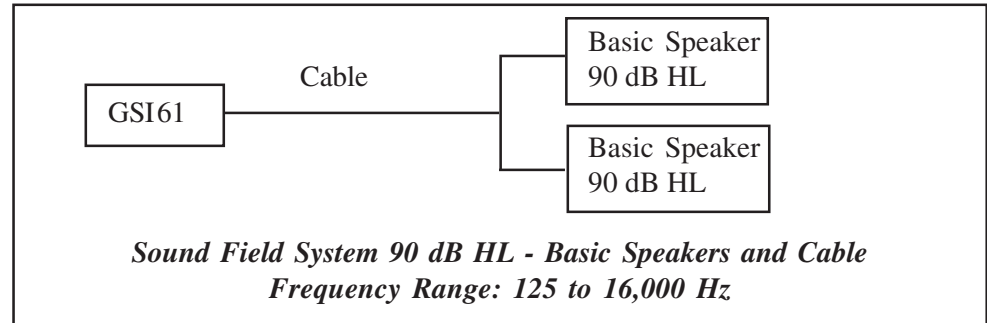

To obtain a maximum level in speech of 96 dB HL, the High Performance Speakers, 1761-9635, may be used.

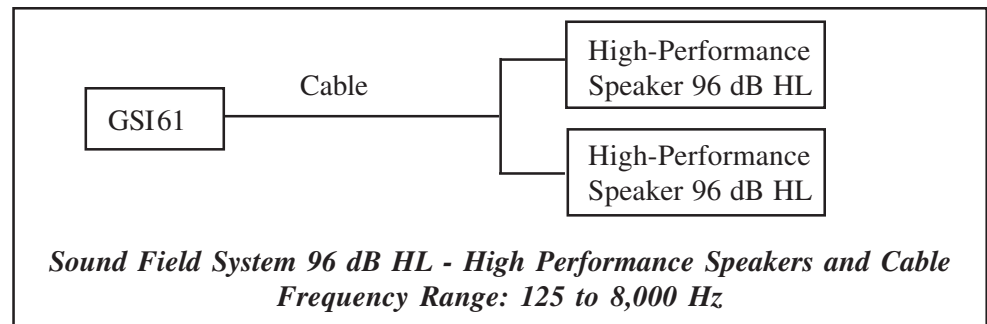

For additional output capability (to 102 dB HL guaranteed maximum level in speech) use the High Performance Sound Field System with Booster Amplifier, 1761-9639, as shown below.

**Note:** The Booster amplifier can only be used with the High Performance speakers. Use of the Booster Amplifier with the basic speakers will/can damage the speakers.

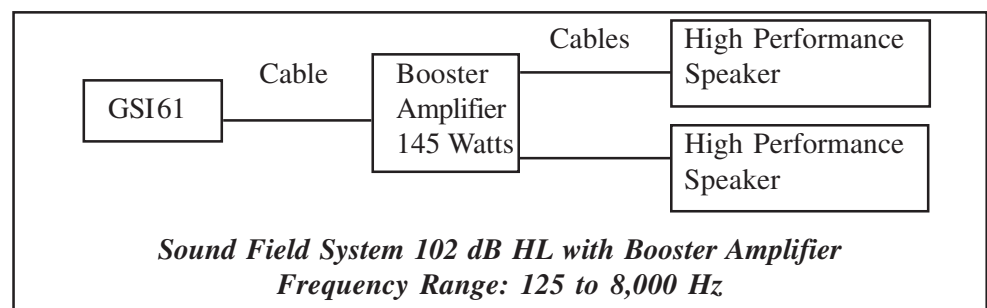

Blank page.

# Operation

---



3

## Preliminary Checks

Before starting any procedures using the GSI 61 Clinical Audiometer, ensure that the power cord is plugged in a properly grounded receptacle. Check also that all cords from the transducers, handswitch (if used), and printer fit securely in their receptacles on the rear and side panels. If speech testing with recorded voice is to be performed, check that the CD or tape unit is connected and operating properly. Turn on the GSI 61 and allow to warm up for 10 minutes.

**CAUTION!** Handle earphones, bone vibrator, and insert earphones with care. Do not drop them nor allow them to be banged together. Severe mechanical shock can alter their operating characteristics which may require that transducers be replaced.

## Patient Instructions

### Noise Recovery Period

Exposure to high levels of sound - unmuffled lawn mowers, many power tools, motorcycles, rock music, gunfire - tends to create a temporary threshold shift (TTS) which diminishes with time after exposure. Any patient tested soon after such exposure will manifest a hearing loss that does not accurately reflect the normal hearing threshold. It is important that the testing procedure prescribe some time interval, usually 16 hours, between the high level sound exposure and the actual hearing test.

### Instructing the Patient

Try to put the patient at ease before beginning the procedure. Explain to the patient:

- a. How the test will be administered.
- b. What he or she should be listening for. Explain that the sounds may be different; some may be soft, some loud.
- c. The purpose of the test is to find the faintest tone which can be heard and it is important to listen carefully. Explain that he or she should respond by raising a finger or hand, or by pressing the handswitch, as soon as the faintest tone is heard. As soon as the tone is no longer heard, the finger/hand should be lowered or the handswitch should be released.
- d. Let the patient know that at first each ear will be tested separately.

### Placement of the Earphones

Prior to positioning the earphones on the patient's head, inspect the ear canals for any blockage due to cerumen or foreign objects. Recognize that soft-walled ear canals may collapse under the earphones and this may lead to incorrect threshold levels. Insert phones might be used in these cases. Eliminate all obstructions, such as glasses, hair, or hearing aid, between the earphone and the patient.

### Placement of the Insert Phone

Center the earphone over both ears and adjust the headband so that it rests solidly on the crown of the head and exerts pressure on both ears. Place the earphone with the red connector over the patient's right ear and the earphone with the blue connector over the left ear.

If insert phones are used, push the correctly sized eartip onto the earphone and then place the insert phone securely into the patient's ear. When using the paired E•A•R insert phones, follow the manufacturer's recommended procedure for eartip placement and insertion.

### Placement of the Bone Vibrator

The bone vibrator may be placed on the promontory of the mastoid process or on the forehead, whichever has been selected for calibration.

# Routine Test Procedures

The following procedures are in compliance with the current ANSI and ISO recommendations for Manual Pure Tone Threshold Audiometry.

## Preliminary

- a. Turn on the instrument and allow it to come to operating temperature.
- b. Check that the transducers and other system components are operating properly.
- c. Seat the patient comfortably in the test area.
- d. Explain the test procedure.
- e. Assist the patient with the earphones or bone vibrator placement.

## Patient Familiarization

- a. Select the proper output transducer routing to the desired ear.
- b. Demonstrate the 1000 Hz tone at 40 dB HL (or at a level estimated to evoke a prompt and clear response) to the patient. The tone duration should be between one and two seconds.
- c. Set the Channel 1 attenuator to -10 dB.
- d. Practice: beginning with the tone continuously on, gradually increase the intensity by rotating the Channel 1 attenuator until a response occurs. Switch the tone off for at least 2 seconds, then present the tone again at the same level. If there is a second response, proceed with a threshold measurement. If the second response does not occur, repeat this step.

## Threshold Determination (Pure Tone): Modified Hughson-Westlake

- a. The level of the first presentation should be 10 dB below the level at which the patient responded during the familiarization session. Present the tone for a period of one to two seconds. The time between presentations can be varied, but should not be shorter than the test tone itself. After each failure to respond to the signal, the level is increased by 5 dB until the first response is given. After the response, the intensity is decreased 10 dB and another ascending process is begun.
- b. The threshold is considered to be the minimum intensity setting at which a response has occurred two out of three times at a single level. Record this setting by pressing the Save pushbutton or by making a notation on an audiogram form.

### Test Procedure

- a. Test the better ear first.
- b. Repeat the sections on Patient Familiarization and Threshold Determination for each tone setting in the following order: 1000 Hz, 2000 Hz, 4000 Hz, 8000 Hz. Retest 1000 Hz followed by 500 Hz and 250 Hz. If there is a difference of 20 dB or greater between octaves, test the inter-octave frequencies, i.e. 750 Hz, 1500 Hz, 3000 Hz, and 6000 Hz. Record these settings by pressing the Save pushbutton with each threshold level.
- c. Repeat this procedure with the other ear.
- d. Determine if masking should be used. The use of masking in the contralateral ear (non-test ear) is indicated if there is a difference in threshold between the two ears of approximately 35 dB or more. If necessary, repeat the testing with masking and again record the testing process.

### Spondaic Speech Testing, Speech Reception Threshold (SRT)

- a. Instruct the patient that he or she will be hearing words that have two parts, such as “mushroom” or “baseball.” The patient should repeat the words and if not sure, he or she should not be afraid to guess.
- b. Using either live voice or recorded speech, present the standardized word lists W-1 and W-2 (Appendix 1 in the guide), testing the better ear first. Start 20 dB above the 1000 Hz pure tone threshold level. Present one word on the list and, if the response is correct, lower the level by 2 dB. Continue until the patient has difficulty with the words. When this occurs, present more words for each 2 dB step.
- c. The Speech Reception Threshold (SRT) is recorded at 2 dB above the level at which the patient cannot repeat any words correctly.

### Speech Discrimination (PB Words)

- a. Instruct the patient that he or she is to repeat the words presented.
- b. Using either live voice or recorded speech, present the standardized PB word list W-22 (Appendix 1 in this guide). Present the words at a level comfortable to the patient; at least 30 dB and generally 35 to 50 dB above the 1000 Hz pure tone threshold. Using the scorer buttons on the front panel, press the “Correct” button each time the right response is given and the “Incorrect” button each time a wrong response is given.
- c. The Discrimination Score is the percentage of words repeated correctly:  $\text{Discrimination \% at HL} = 100 \times \text{Number of Correct Responses} / \text{Number of Trials}$ .

# Special Test Procedures

---

## 4

This section describes some special test procedures that can be used with the GSI 61 Clinical Audiometer. While we recognize that not all of our customers feel that this information is necessary, we have received requests to include this type of testing information in our manuals.

The flexibility of the GSI 61 allows for preference choices in test setup and operations. The operator makes the channel, routing, transducer and presentation mode selections which are appropriate to the test requirements. The Interrupt pushbutton may be selected for continuous and automatic stimulus presentations, or the tone bar may be pressed for manual presentation. Channel 1 and Channel 2 may be interlocked for simultaneous presentations or operated independently. Each channel can be routed Right, Left or Left/Right.

## Alternate Binaural Loudness Balance (ABLB) or Fowler Test

The perceived growth of loudness of a suprathreshold tone in an impaired ear may differ from the compared growth of loudness of a tone of identical frequency in the normal ear. Recruitment, if present, may be found.

1. Assist the patient with the placement of the earphones.
2. Determine the threshold level for each ear at all frequencies being tested.
3. Select the ear to serve as the reference ear, typically the ear with the better hearing sensitivity. This ear will receive the tone at a fixed intensity.
4. Select the ALternate tone format. Channel 1 and Channel 2 will automatically interlock in this selected format. The Interrupt button should be selected for automatic presentation of the tone. The tone will alternate from Channel 1 at the rate of 400 msec on, 400 msec off followed by Channel 2 at 400 msec on, 400 msec off.
5. The tone may be manually alternated between Channel 1 - Right and Channel 2 - Left by pressing the tone bar (with the Interrupt in the off position) for the duration of the time the signals are to be presented.
6. To increase the test reliability, the patient should be given several trials to judge whether a variable tone is “softer,” “equal to,” or “louder” than the tone in the reference ear.
7. Set the intensity of the tone for each channel to 20 dB above the threshold of each corresponding ear.
8. Alternate the tone presentation between the ears.
9. Keeping the intensity fixed in the reference ear, vary the intensity level of the tone presented to the test ear. Note the level at which the patient judges both of the signals to be of equal loudness.
10. Repeat the above procedure increasing the intensity of the tone for the channel routed to the reference ear by 20 dB each time until an intensity of 80 to 90 dB is reached. Identify the dB HL of the tone necessary to “balance” in loudness the tone in the reference ear at each level. This procedure is followed for each frequency to be balance tested.

## Monaural Loudness Balance (MLB) Test

A comparison of perceived loudness growth is made between two different frequencies on the same ear.

1. The frequency where the best hearing is detected is used as the “reference” frequency for the comparison of perceived loudness with tones at the impaired frequency. There should be a difference of at least 25 dB between thresholds at each frequency tested.
2. The output (tone) is routed to a single earphone (Right or Left).
3. The procedure is essentially the same as the ABLB test. The signal is manually alternated from frequency to frequency. The reference frequency is increased in intensity in 20 dB steps above threshold.
4. Instruct the patient to indicate when the two frequencies appear to be of equal loudness.
5. The level at which the loudness of the test frequency balances the loudness of the reference frequency is noted.

## Short-Increment Sensitivity Index (SISI)

Patients exhibiting cochlear pathology are better able to detect small increments in intensity at low sensation levels than normally hearing subjects or subjects with pathologies located elsewhere in the auditory system. A continuous tone is presented to the test ear at 20 dB SL. Every five seconds, a selected increment in intensity is introduced to the continuously presented tone for a duration of 200 msec.

1. Using earphones, establish the threshold of the test ear for the selected frequency.
2. Carefully instruct the patient prior to testing that a faint but steady sound will be heard and a small jump in loudness may occasionally occur. The patient is instructed to respond each time he is certain that the jump is heard.
3. Press the SISI button and the desired dB Step size.
4. Select Tone or FM and route the stimulus to the test ear through Channel 1 (Right or Left). Set the intensity for Channel 1 to 20 dB above threshold. Masking noise may be routed to the contralateral ear through Channel 2.
5. Press the Interrupt button for Channel 1 (and Channel 2 if masking is being used).
6. Familiarize the patient with responding to noticeable increments in intensity by providing practice trials selecting each available dB step (5 dB, 2 dB or 1 dB).
7. Present twenty 1 dB increments with the patient responding each time an increment is detected. After the fifth, tenth, and fifteenth presentations, the increment can be omitted or raised to 5 dB as a check for validity of the response and to insure against “rhythmic condition”.
8. Score each correct response by pressing the Correct button and each wrong response by pressing the Incorrect button. The SISI percent score is displayed on the status screen.

### Modifications to the SISI test

1. Select step sizes larger than 1 dB at 20 dB SL.
2. Present 1 dB increments at increasingly higher sensation levels.
3. Vary step sizes from 1 dB to 5 dB at 20 dB SL in both ears.
4. Present 1 dB increments at increasingly higher sensation levels to both ears.

## High Frequency Testing (Optional)

The administration of some aminoglycoside antibiotics and/or chemotherapies can cause a sensory-neural hearing loss, typically observed in the high frequency ranges (above 12 kHz).

1. Installation of the High Frequency option is necessary for this test capability. Contact your GSI representative for additional information.
2. Install the High Frequency earphones as shown in the following figures: High Frequency to Booth, or High Frequency - No Booth.
3. Select the High Frequency audiogram display format by pressing the High Freq pushbutton on the front panel.
4. Assist the patient with the placement of the High Frequency earphones.
5. Proceed as with pure tone threshold testing, recording the thresholds onto the audiogram.

### High Frequency Testing: Setup Diagrams

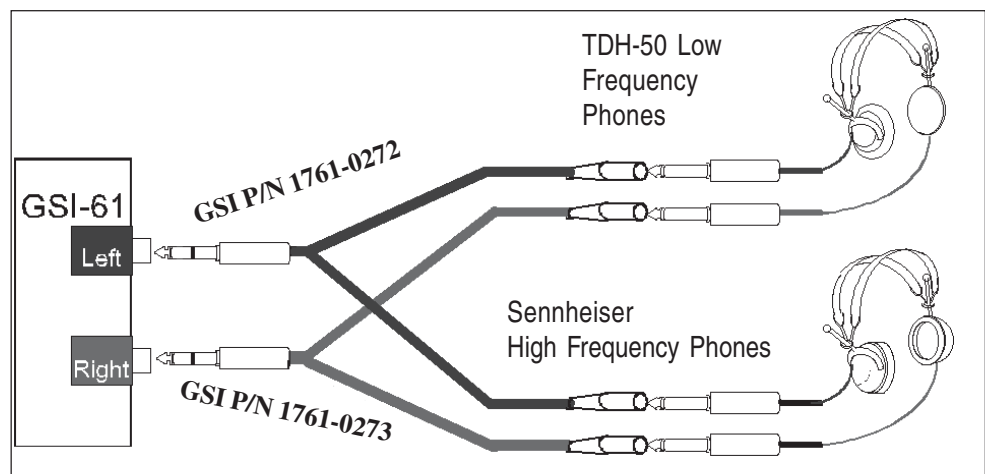

*High Frequency - No Booth*

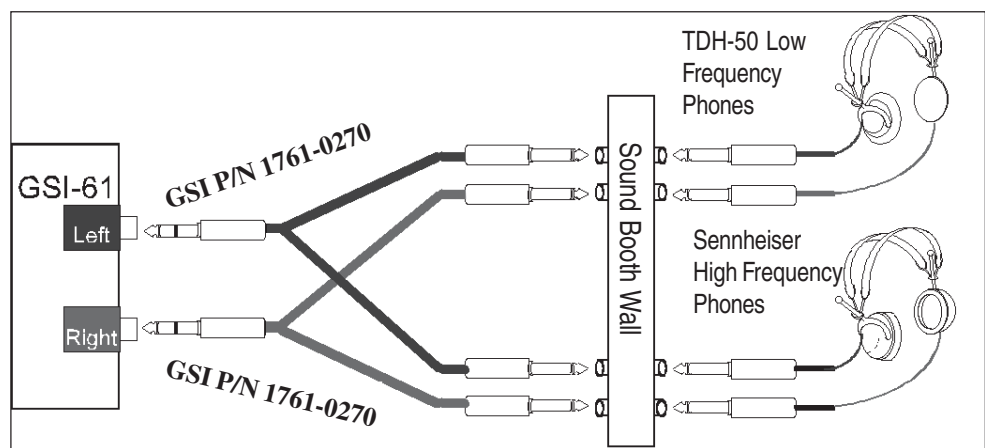

*High Frequency to Booth*

## Sensorineural Acuity Level (SAL) Test

A modification of the Rainville Method.

A procedure for the measurement of sensorineural sensitivity comparing threshold shifts produced by bone conducted masking noise in normal hearing subjects and in patients.

This narrow band masking allows for a noise intensity signal necessary to achieve the desirable greater threshold shifts at lower frequencies.

1. Assist the patient with earphone (or insert phone) placement and with positioning the bone vibrator on the forehead.
2. Using Channel 1 with Phone and Tone selected, establish the patient's air conduction thresholds in each ear for each frequency to be tested. Frequencies between 250 and 4000 Hz are suggested as the most useful for the purposes of this test.
3. Using Channel 2, select Bone and Narrow Band Noise.
4. Determine air conduction thresholds again for each ear in the presence of bone conducted noise.
5. Determine the patient's threshold shift caused by noise.
6. The "sensorineural loss" at each frequency is the difference between the patient's threshold produced with the noise and the amount of shift normal hearing adults experience under the same conditions.

## Hearing Aid Evaluation

### Unaided Test

Based on the Carhart Method (1946).

1. Seat the patient in a sound field room (6 ft by 6 ft) at a distance equal to one meter from the speakers. The patient's ears should be on a plane with the face of the speaker.
2. The Insert phone may be selected as an alternate transducer for hearing aid evaluation.
3. Adjust Ext A and/or Mic to peak at an average of 0 on the VU meter.
4. Score each correct response by pressing the Correct button and each wrong response by pressing the Incorrect button to obtain an unaided Speech Reception Threshold (SRT). Live speech or recorded spondees will be presented in the test ear.
5. Continue with unaided word discrimination testing to obtain a word discrimination score.
6. Obtain an unaided estimate of tolerance limits (Uncomfortable Loudness Level or UCL). The patient should be told that the clinician's voice will be uncomfortably loud, but he should report whether he actually feels a pressure, a tickle or pain. Beginning at the speech reception threshold level, the patient is requested to answer simple questions while the attenuator for the selected channel is increased in 5 dB steps. Continue this procedure until a reading of 80 to 90 dB HL is reached or until the patient indicates that the sound is painful.

### Aided Test

The following aided tests are then performed for comparison.

1. Obtain an aided Speech Reception Threshold in the sound field room with the patient wearing the hearing aid to be evaluated.
2. The attenuator for the channel routed to the aided ear should be set to 40 dB HL (comfort setting).
3. Instruct the patient to turn up the volume of the hearing aid until the tester's voice is comfortably loud. Hearing aid volume should remain at this setting throughout the test.
4. Present spondees, beginning at the 40 dB setting and attenuating the intensity until the aided threshold is reached.
5. The aided discrimination score can then be obtained by initially setting the intensity to 30 to 40 dB above the aided threshold. The hearing aid's volume should be set for a 40 dB HL speech input.
6. Obtain aided measurement of discomfort or tolerance limits with the same gain control setting.
7. The measurement of efficiency in noise can be determined.
  - a. Set the hearing aid gain for a 50 dB HL speech input level.
  - b. Present word discrimination material at 50 dB HL through Channel 1 to the aided test ear.
  - c. Route speech or white noise to the aided test ear through Channel 2.
  - d. Increase the noise gradually until the words can no longer be repeated.
8. Continue comparative tests with each hearing aid in evaluation.

## Tone Decay Test

Patients with retrocochlear pathology of the eighth nerve exhibit a rapid “abnormal auditory adaption” or a “temporary threshold drift” in response to a continuous pure tone presentation.

### Carhart Tone Decay Test (1957)

1. Establish the patient’s hearing threshold for the test ear using earphones or insert phones and selecting a pulsed tone.
2. Instruct the patient to depress the handswitch as soon as a tone is heard, and to release the handswitch only when the tone becomes inaudible.
3. Begin the test with a continuous tone. Set the intensity for the selected channel to 0 dB SL (or 20 dB SL to present an easier listening task). The Interrupt pushbutton may be selected or the Tone bar may be manually depressed for the duration of the test.
4. As soon as the patient responds, begin timing by pressing the Start pushbutton of the scorer/timer. Record the number of seconds the tone sustains audibility with the Timer on the front panel of the GSI 61 (F17).
5. If the tone becomes inaudible before the minute criteria is met, without interrupting the tone presentation, raise the intensity in 5 dB steps until the tone is heard for a full minute.
6. Reset the timer at each increase in intensity level. Continue this procedure until the tone is heard for a full minute, or until an intensity of 40 dB SL is reached.

## Lombard or Voice-Reflex Test

The Lombard Test is based on the principle that individuals monitor their vocal intensity by means of auditory feedback. It is normal for individuals to speak more loudly when exposed to a background of masking noise (approximately 16 to 20 dB above the threshold for the noise).

1. The patient is given a clearly typed paragraph to read aloud into the talk back microphone.
2. Put on the monitor headphones (monitor speaker may also be selected). Adjust Channel and Talk back monitor knobs to appropriate levels.
3. Select Speech Noise as the input signal on Channel 1. Routing should be Left/Right. The output is presented through the earphones or sound field speakers. Channel 2 is not active during this test.
4. Signal to the patient to begin reading. With the Channel 1 attenuator set to an intensity of 0 dB HL, gradually increase the intensity of the noise level.
5. Note the level of masking at which the patient’s voice becomes more intense and compare this level with the degree of supposed patient hearing loss.

## Delayed Auditory Feedback (DAF)

If a person's voice is recorded and played back with a delay of 0.1 to 0.2 seconds, the auditory feedback causes the speaker to slow down or alter his speech in a stuttering manner.

1. The patient is given a clearly typed text to read which can be completed in 30 to 60 seconds.
2. Using patient earphones, or sound field speakers, the test may be performed by routing the stimulus (Ext A) to both ears (Left/Right), and with or without Speech Noise to the non-test ear.
3. The Examiner uses the same monitoring procedure described in Step 2 of the Lombard test.
4. The patient is placed before the talk back microphone and asked to read the text. His reading is tape recorded and timed with the timer.
5. The patient is asked to repeat the reading while the recording of the speaker's voice is routed to the selected transducer with a delay of 0.1 to 0.2 seconds.

**(Note: A three head tape recorder with the appropriate delay capabilities is required.)**

6. The intensity of the signal (controlled by the attenuators) is first set to 0 dB HL and raised 10 dB after each reading is complete until a positive result is seen.
7. Each reading is timed with the timer. A change in the reading rate (3 to 5 seconds), an increase in the vocal intensity, or a stuttering effect indicate that the auditory feedback was heard.

## Staggered Spondaic Word Test (SSW)

1. Using earphones or speakers in a sound field, and an external source of speech, establish the patient's speech threshold relative to the three frequency, pure tone average for each ear.
2. Set the intensity level of the signal for the Channel 1 and Channel 2 attenuators to 50 dB SL. This level may be adjusted for severe hearing loss or tolerance problems. A presentation level of 30 dB SL is suggested when air-bone gaps exceed 20 dB (J. Katz and E. White, unpublished).
3. Forty spondaic words recorded on an external source are presented to the patient in partially overlapping pairs. The patient is asked to repeat both spondees:
  - a. With Channel 1 routed right and Channel 2 routed left, the first syllable of the first spondee is presented to the right ear alone through Channel 1.
  - b. Select the Interlock button and simultaneously present the second syllable of the first spondee through Channel 1 to the right ear, and the first syllable of the second spondee to the left ear through Channel 2.
  - c. The second syllable of the second spondee is then presented to the left ear alone.
  - d. The presentations of the spondees are alternated from ear to ear. (The right ear may receive the first monosyllable and the left ear receives the first monosyllable of the next pair of spondees.) Thus, twenty presentations are right ear first and twenty presentations are left ear first.
  - e. Practice word pairs should be presented to the patient before scoring begins.

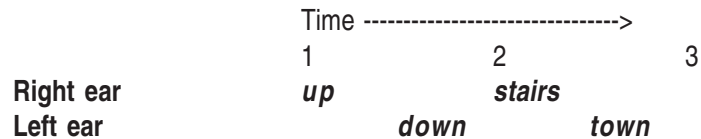

## Doerfler-Stewart Test

It is difficult to maintain consistent supra-threshold responses to auditory signals in the presence of several levels of noise in the same ear. Masking noise can cause confusion and interferes with the ability to judge the loudness of signals.

1. Using earphones or speakers in a sound field, establish a recorded binaural spondee threshold ( $SRT_1$ ). Live voice (Mic) or recorded (Ext A or Ext B) spondees may be routed to each ear (Left/Right) through Channel 1.
2. Raise the speech signal to  $SRT_1 + 5$  with the Channel 1 attenuator without interruption. Speech noise is introduced to both ears (Left/Right) through Channel 2 along with the words.
3. Speech noise is introduced at a low level (0 dB HL is suggested) and is increased in 5 dB increments with the Channel 2 attenuator for each spoken spondee until the intensity level is 20 dB below the  $SRT_1 + 5$ .
4. Obtain the “noise detection threshold” (NDT).
5. Obtain the “noise interference level” (NIL) by increasing noise in 2 dB steps (Channel 2) until the patient stops repeating the spondees.
6. Maintain speech signal intensity (Channel 1) at the same level while increasing the intensity of the noise (Channel 2) in 5 dB steps to a level 20 dB above NIL. Present one word at each increment level.
7. Maintain the noise at this level (Channel 2) and reduce the intensity of spondees in 5 dB steps (Channel 1) to a level 15 dB below  $SRT_1$ . Present one word at each decrement.
8. Decrease the level of noise in 5 dB steps (Channel 2) for each spoken spondee until NIL is reached. Continue to decrease noise level and note the level at which the patient begins to again repeat spondees.
9. Re-establish a speech threshold ( $SRT_2$ ) as in Step 1.

### Modified Doerfler-Stewart Test

This test is performed in one ear, using pure tones and white noise as a masker. Routing selection for Channel 1 (Tone) and Channel 2 (White Noise) should be the same for the ear being tested (left or right).

## Pure Tone Stenger Test

If two tones identical in all ways except loudness are introduced simultaneously into both ears, only the louder tone will be perceived.

### Screening Procedure

1. Assist the patient with the placement of earphones.
2. Use standard audiometric techniques to obtain a record of the patient's "thresholds" at each test frequency in both the good and the poor ear.
3. Interlock the tone bars of Channel 1 and Channel 2. Route the tone to both ear simultaneously (Channel 1 - Right; Channel 2 - Left).
4. Select the desired frequency. Set the attenuator for the channel routed to the better ear at a level 10 dB above the threshold for that ear. Set the attenuator for the channel routed to the poorer ear at a level 10 dB below the threshold for that ear. Present the simultaneous tones.

### Obtaining Minimum Contralateral Interference Levels

1. Present a tone at 10 dB SL to the better ear while simultaneously (Channel 1 and Channel 2 interlocked) presenting a tone at 0 dB HL to the poorer ear.
2. Maintain the same intensity level in the good ear but raise the intensity for the poorer ear by 5 dB and present the two tones.
3. With each response, continue to present the tones to each ear simultaneously. Raise the tone routed to the poorer ear by 5 dB each time the patient fails to respond.

### Modified or Speech Stenger Test

Used, as is the Pure Tone Stenger test, in unilateral hearing losses to determine the level of contralateral interference when a speech signal is delivered to the ear with the greater loss. (The difference in SRT between the ears should be at least 20 to 25 dB).

1. Follow the procedure described above (Pure Tone Stenger) using Speech stimuli.
2. Spondees are presented simultaneously by live voice or recorded speech at a level 10 dB above the better ear threshold and 10 dB below the threshold for the poorer ear.
3. The minimum contralateral interference is determined in the same manner previously described using spondees.
4. The minimum contralateral interference is the lowest intensity level in the poorer ear at which the patient stops repeating 2 or more spondees correctly.

# Routine Maintenance

# 5

## Biological Calibration Check

The microprocessor based circuit design of the GSI 61 Clinical Audiometer should provide trouble-free service for a long time period. It is recommended however to routinely make and file the audiogram of one person who will be available for this purpose. This person (or group of persons) should have a known stable audiometric curve that does not exceed 25 dB HL at any frequency. This procedure should start when the GSI 61 is first installed and then be continued. Remember that individual threshold can shift by as much as 5 dB from day to day; however variations that exceed this range may point to difficulties which require attention.

## Periodic Checks

The routine maintenance checks described below may point to the source of, and cure for some instrument problems. If they do not, the instrument should receive technical service before further use. The checks should be made at periodic intervals, even if biologic checks reveal no problems. These procedures presuppose normal hearing of the person doing the checking.

### Earphone and Bone Vibrator Cords

With extended use, earphone and bone vibrator cords tend to fray internally at the connectors. This fraying will ultimately either decrease or increase the signal level or cause signals to come and go as the cord is flexed.

To check for either condition, turn on the GSI 61. Set the HL to a comfortably audible level. Activate both Interrupt buttons to normally ON. Flex the cord next to the plug at both ends of the each earphone. Listen for an intermittent signal, abrupt changes in the signal level, or a scratchy sound riding over the signal that coincides with the flexing of the cord. The presence of any of these conditions signifies that the cord should be replaced.

Repeat the test for the other earphone, the bone vibrator and the insert phones.

### Hum and Noise

This check can be made during the check for attenuator noise. With the GSI 61 initialized to Tone test type and the Channel 1 Interrupt button in the normally ON mode, turn the Channel 1 Hearing Level control from 0 to 60 dB HL. Listen for low frequency hum (60 or 120 Hz) and any other noise (hiss or low rushing sound) at all attenuator levels through the earphone. Some audible noise at levels above 70 dB is permissible. If these noises are detected below 70 dB, the audiometer should be scheduled for maintenance. Repeat this procedure with the Channel 2 Hearing Level control.

### **Distortion and Frequency Shift**

This check can be made by listening to the GSI 61's output through the earphones and pressing all frequencies (in the 125 Hz to 12000 Hz range) at a loud, but not uncomfortable level (70 to 80 dB HL for normal ears). Listen also to ascertain that the signal frequencies change appropriately when the Frequency ↵ and ⊗ pushbuttons are operated. If distortion is heard in one earphone but not the other, the chances are high that the earphones are at fault and should be replaced. In any case, the audiometer should be scheduled for immediate maintenance.

### **Speech Level Check**

To check the speech level, select Ext. A, Channel 1. Place the earphones on a person with a hearing loss not in excess of 25 dB. If intelligible speech is not heard with the Channel 1 Hearing Level control set at 40 dB or less, the audiometer or the external device should be scheduled for technical service. To double check a possible problem with the audiometer, check the speech level with live voice through the Mic.

### **Internal Controls Check**

Should the front panel controls lock into one state and you are not able to change any of the parameters, turn off the power. Wait one minute and then power on.

### **Bone Vibrator Check**

This check must be performed in a quiet ambience or in a sound room. With the frequency Hz set to 2000 Hz, the Channel 1 HL set at 40 dB HL and the bone vibrator positioned properly, the tone should be clearly audible to a person with a hearing loss not in excess of 25 dB. When a bone vibrator fails this test, the calibration should be verified. If the bone vibrator cannot be calibrated to specifications, it should be replaced.

### **Masking Level Check**

Select the Tone test type. Activate the Channel 2 Interrupt button so that it is on. Listen for a smooth, even hiss with the Channel 2 Hearing Level control set at 50 dB HL.

### **Talk Forward Check**

Speech should be clearly audible (in the earphones) when spoken in a normal tone with the Talk Forward dB HL control set at 45 dB HL.

## Calibration Reference Levels

It is recommended that each GSI 61 receive a thorough calibration certification once a year. If periodic checks are also desired, the tables in this section provide the SPL values per frequency for each transducer. If the measured values are not within  $\pm 5$  dB at 125, 6000, 8000 and 12,000 Hz in the earphones, the GSI 61 should be scheduled for immediate maintenance.]

### Sound Pressure Levels for Pure Tones with TDH 50P Earphones SPL values with TSH 50P earphones for 70 dB HL setting

Frequency	125	250	500	750	1000	1500	2000	3000	4000	6000	8000	12000	Speech
<u>IEC 303</u>	117.5	96.5	83.5	78.5	77.5	77.5	81.0	79.5	80.5	83.5	83.0	87.5*	90.0
<u>IEC 318</u>	115.0	97.0	83.5	79.0	77.5	77.5	79.0	81.5	82.0	86.0	85.5	82.5*	90.0

\*Interpolated

**Note:** The 125 Hz through 8000 Hz values are based on ANSI S3.6-1989 and ISO 389-1991 Standards.

### Reference Levels for Pure Tones with E•A•R Tone Earphones SPL values with the E•A•R Tone Earphones for 70 dB HL setting

Frequency	125	250	500	750	1000	1500	2000	3000	4000	6000	8000	Speech
<u>IEC 126</u>	96.0	84.0	75.5	72.0	70.0	72.0	73.0	73.5	75.5	72.0	70.0	82.5
<u>IEC 711</u>	98.0	87.5	79.5	76.0	75.5	79.5	81.5	83.0	85.0	86.0	85.5	88.0

**Note:** The 125 Hz through 8000 Hz values are based on ISO 389, Amendment 1.

### Effective Masking Values for Pure Tones - ISO 8797 Narrow band noise SPL value for 70 dB HL setting

Frequency	125	250	500	750	1000	1500	2000	3000	4000	6000	8000	12000	Speech Noise
<u>IEC 303</u>	121.5	100.5	87.5	83.5	83.5	83.5	87.0	85.5	85.5	88.5	88.0	92.5*	90.0
<u>IEC 318</u>	119.0	99.0	87.5	84.0	83.5	83.5	85.0	87.5	87.0	91.0	90.5	87.5*	

\*Interpolated

**Note:** For narrow band noise, the level control is calibrated in dB of effective masking. The SPL in each one-third octave band centered at each frequency is calibrated to a level 3 dB above the standard reference level for this frequency.

**Bandwidths for Narrow Band Masking Sounds  
(Pass Band Upper and Lower Frequency Limits at 3 dB Points)**

<u>Center Frequency, Hz</u>	<u>Lower Limits, Hz</u>	<u>Upper Limits, Hz</u>
125	105 - 111	140 - 149
250	210 - 223	281 - 297
500	420 - 445	561 - 595
750	641 - 668	842 - 892
1000	841 - 891	1120 - 1190
1500	1260 - 1340	1680 - 1780
2000	1680 - 1780	2240 - 2380
3000	2520 - 2670	3370 - 3570
4000	3360 - 3560	4490 - 4760
6000*	5050 - 5350	6730 - 7140
8000*	6730 - 7130	8980 - 9510
12000*	10092 - 10570	13500 - 14275

\* Due to the limitations of the existing couplers and artificial ears, acoustic measurements are not required.

**Bandwidth for Narrow Band Masking Sounds (High Frequency)  
(Pass Band Upper and Lower Frequency Limits at 3 dB Points)**

<u>Center Frequency, Hz</u>	<u>Lower Limits, Hz</u>	<u>Upper Limits, Hz</u>
8000	6730 - 7130	8980 - 9510
9000	7570 - 8020	10100 - 10700
10000	8410 - 8910	11220 - 11890
11200	9420 - 9980	12570 - 13320
12500	10510 - 11140	14030 - 14870
14000	11770 - 12470	15710 - 16650
16000	13450 - 14250	17960 - 19030
18000	15138 - 16042	20196 - 21413
20000	16820 - 17815	22440 - 23792

**Bone Vibrator (B71) Calibration Values for Non-occluded Test Ear  
Mastoid Placement (ANSI 3.43 and ISO 7566)**

<u>Frequency</u>	<u>250</u>	<u>500</u>	<u>750</u>	<u>1000</u>	<u>1500</u>	<u>2000</u>	<u>3000</u>	<u>4000</u>	<u>6000</u>	<u>8000</u>	<u>Speech*</u>	
<u>Radioear B71 with non-occluded ear</u>	67.0	58.0	48.5	42.5	36.5	31.0	30.0	35.5	40.0	40.0	55.0	dB re: 1 N

\* Tentative

**Notes:** These values were obtained with 30 to 35 dB effective masking by air conduction to the non-test ear.

1. The above values apply for the mastoid position using the Bruel and Kjaer type 4930 artificial mastoid, having manufacturer's serial numbers of 526226 or higher, and type B71 bone vibrators used with a P-3333 headband.
2. These values are from ANSI 3.43 and ISO 7566.
3. No standard reference equivalent threshold level for speech has been established for bone vibrators.
4. The reference level used for the calibration of speech is 12.5 dB above the 1000 Hz level or at a force level of 51.2 dB re: 1 N.
5. The values in the table are based on 0 dB HL settings.

**Bone Vibrator (B71) Calibration Values for Non-occluded Test Ear  
Forehead Placement (ANSI 3.43 and ISO 7566)**

<u>Frequency</u>	<u>250</u>	<u>500</u>	<u>750</u>	<u>1000</u>	<u>1500</u>	<u>2000</u>	<u>3000</u>	<u>4000</u>	<u>6000</u>	<u>8000</u>	<u>Speech*</u>
<u>Radioear B71 with non-occluded ear</u>	79.0	72.0	61.5	51.0	47.5	42.5	42.0	43.5	51.0	50.0	63.5* dB re: 1 N

\* Tentative

**Speaker Reference Threshold Levels Re: 20 mPa**

<u>Frequency</u>	<u>125</u>	<u>250</u>	<u>500</u>	<u>750</u>	<u>1000</u>	<u>1500</u>	<u>2000</u>	<u>3000</u>	<u>4000</u>	<u>6000</u>	<u>8000</u>	<u>12000</u>	<u>Speech</u>
<u>45° Azimuth</u>	23.5	12.0	3.0	0.5	0.0	-1.0	-2.5	-9.0	-8.5	-3.0	8.0	11.5	12.5
<u>0° Azimuth</u>	24.0	13.0	6.0	4.0	4.0	2.5	0.5	-4.0	-4.5	4.5	13.5	13.5	16.5

<u>Frequency (Hz)</u>	<u>8000</u>	<u>9000</u>	<u>10000</u>	<u>11200</u>	<u>12500</u>	<u>14000</u>	<u>16000</u>
<u>45° Azimuth</u>	8.0	10.5	11.0	10.0	11.5	16.0	43.5
<u>0° Azimuth</u>	13.5	15.5	15.5	14.0	13.0	18.0	44.5

**Notes:**

1. Forty-five degree Azimuth reference threshold values are based on ISO 8253-2.
2. Zero degree Azimuth reference threshold values are based on ISO 226-1.

**Reference Levels for Pure Tones with Sennheiser HDA 200  
SPL Values with the Sennheiser HDA 200 Earphones for 0 dB HL Setting**

<u>Frequency (Hz)</u>	<u>8 K</u>	<u>9 K</u>	<u>10 K</u>	<u>11.2 K</u>	<u>12.5 K</u>	<u>14 K</u>	<u>16 K</u>	<u>18 K</u>	<u>20 K</u>
<u>Sennheiser HDA 200</u>	16.0	17.0	21.5	21.0	27.5	37.5	58.0	83	105

Reference threshold values based on ISO/TC 43/WG 1 N 190 and Tom Frank, PhD; "High Freq. Hearing Thresholds in Young Adults Using a Commercially Available Audiometer", *Ear and Hearing*, Vol. 11 No. 6, 1990.

## The Message “CAL”

The calibration for the GSI 61 is stored in the system’s memory, and this data is continually monitored. If an error should be found in the calibration memory, the message “CAL” is displayed in the appropriate channel’s intensity area. “CAL” is displayed as long as the faulted transducer and stimulus combination is selected. The channel is forced into an off condition and cannot be turned on until a new stimulus and transducer combination is selected. When the message “CAL” appears in either Channel 1 or Channel 2, note the specific combination selected. Try the same combination on the alternate channel. Or you might power down and power up to attempt to clear the fault. Should “CAL” continue to be displayed, contact your service representative and report the specific combinations and conditions used.

## The Message “Help’

Should the message “Help” appear in the message area of the display, the GSI 61 will enter a lock out mode which will disable all front panel operations. In addition to the message “Help”, code numbers will appear. These numbers are important as they indicate the possible source of the problem.

**It is extremely important that you record these numbers.**

Reset the GSI 61 by turning off the power, waiting 30 seconds, then turning it on. Should “Help” continue to be displayed, contact your service representative and report the specific conditions used.

## Line Voltage Brownout and Interruptions

The GSI 61 is designed to protect against abnormal AC power conditions by returning to the power-up initialization settings; thereby protecting the unit against unwanted conditions at the transducers. This will automatically occur when interference is not too severe. However, under extreme conditions the GSI 61 will enter a lockout mode which will not permit front panel operations. This can be rectified by simply powering down for approximately thirty seconds and then restarting operation.

# Remote (RS 232) Option

---



## Description

The interface option for the GSI 61 Clinical Audiometer allows electronic transmission of test parameter information from the GSI 61 to a remote external computer; the user may also remotely control the operations of the GSI 61 by an external computer. The RS 232 option can only be used with those instruments which have the Remote board installed.

Two communication protocols are available with the GSI 61. One is identical to the protocol used on the GSI 16 Audiometer allowing the GSI 61 to be used in the same environment as that instrument. The other interface protocol adds the features provided by the GSI 61 such as the ability to transmit complete audiogram information with a single push of the Data Transmit button, and High Frequency audiometry.

## Operation

The GSI 61 RS 232 option functions in all operative test modes of the audiometer. A software link is enabled by pressing the Remote button on the instrument's front panel; a message to this effect can be observed on the LCD display. The link is disabled by depressing the Remote button again. Note that the word "Remote" will be erased. The Remote indicator must be displayed in order for the transfer of information to occur. Actual data capture and transfer occurs when the Data Transfer button on the front panel is pressed. When the Data Transfer button is pressed; all pertinent unit switch settings and display information is internally buffered by the GSI 61 for transmission through the RS 232 serial interface to an external computer. During the period of data capture and to the end of transmission of the data record, "Data Transfer" is displayed on the LCD panel (activation will be 0.5 seconds, minimum).

The GSI 61 is configured as a DCE (Data Communications Equipment) device and would normally connect to a remote device configured as a DTE (Data Terminal Equipment) device. Hardware handshaking (RTS/CTS) and software handshaking (xon/xoff) are provided to control data flow.

## Configuration

The configuration of the GSI61 Remote interface must be set to match the interface configuration of the computer. This configuration is set by your Grason-Stadler service representative during installation. A dip switch (S1) is provided on the serial interface board to configure the interface for baud rate, parity and number of data bits, number of stop bits and data flow control; this switch is inside the GSI 61 and is not accessible by the user. These settings are read on powerup and the hardware is initialized appropriately.



# Data Flow Control Operation

## Hardware Flow Control

When hardware control is selected, RTS/CTS handshaking is used. The remote device may use the RTS signal to allow or inhibit data transmission for the GSI 61 to the remote device. When the RTS signal is set true by the remote device, the GSI 61 is enabled to transmit data. When the RTS signal is set false by the remote device, the GSI 61 is inhibited from transmitting data. The remote device should insure that RTS is set true prior to requesting data from the GSI 61. If the RTS signal is false at the start of a transmission, or goes false during a transmission, the GSI 61 will wait for 6 seconds for the signal to return true. If this does not occur, the transmission is aborted and the error message "Not Available" will temporarily flash.

The GSI 61 uses the CTS signal to allow or inhibit data transmission from the remote device to the GSI 61. When the CTS signal is set true by the GSI 61, the remote device may transmit to the GSI 61. When the CTS signal is set false by the GSI 61, the remote device must not transmit to the GSI 61. Failure to comply with this condition may result in the loss of data transmitted to the GSI 61.

The GSI 61 will set the CTS line false to prevent data transmission by a remote computer. This occurs while processing a completed input command, while printing, while the GSI 61 is transmitting a record and whenever the remote device is not enabled through the Remote button.

## Software Flow Control

When software flow control is selected, XON/XOFF handshaking is used. Software XON/XOFF flow control is available to allow software commands from the external computer to start and stop the flow of data from the GSI 61. The XOFF character used is the ASCII control character [DC3]. The XON character used is the ASCII control character [DC1]. Sending XOFF to the GSI 61 pauses its transmission; sending XON to the GSI 61 resumes the transmission. Once XOFF is received by the instrument, XON must be received within 6 seconds. If it is not received within this time constraint, the error message "Not Available" is flashed on the front LCD panel.

## Cable Connections

The GSI 61 remote interface provides a serial interface consisting of RxD (Received Data), TxD (Transmitted Data), RTS (Request To Send), CTS (Clear To Send) and ground signals at the end of the supplied DB-25 male connector. This cable, which is supplied with the Remote Option, can also be purchased as an Apple "Hayes Modem" cable, available from Apple dealers.

**IMPORTANT:** Make sure this cable incorporates all the signals in the figure below!

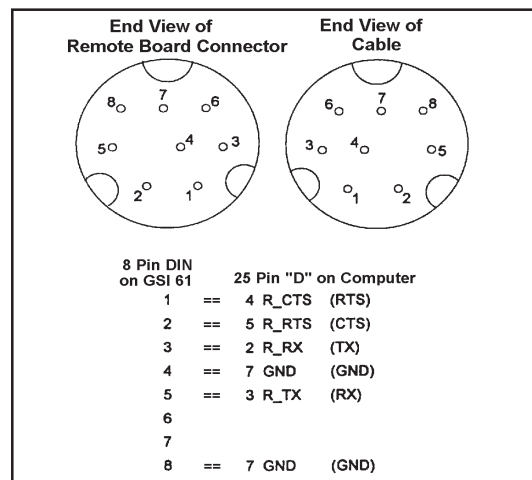

## Data Transfer

### Record and Field Formatting

Communication with the remote device is performed by sending and receiving information in “records”. Each type of information has its own record format. Each record is divided into “fields” which contain specific information. All records are formatted with a predefined, fixed length format. The generic format for all records is:

Record Prefix	Record Type	Data Fields	Checksum	Record Terminator
---------------	-------------	-------------	----------	-------------------

The record prefix consists of a “:” character and denotes the start of a record. Input records do not contain a checksum. The record terminator consists of a “CR”, “LF” sequence. Each record consists of fixed length data fields with any unused or Zero data fields filled with a “0”. All records consist of a sequence of printable ASCII characters from the set of “0” to “9”, “A” to “G”, “-”, “:”, “.”, “\_”, “CR” and “LF”. All multiple character ASCII fields will be right justified with unused character positions filled with “\_” characters. Positive numeric values will not contain a “+” sign; this will be implied. Negative values contain a “-” sign in any character position to the left of the most significant digit if the number. Unless specified, the decimal point for non-integer numbers will not be included in the character sequence.

### Checksums

Checksums will be calculated so as to maintain compatibility with the GSI 16 as the mod 256 sum of all preceding characters on the record, including the “:” prefix, and stored as two HEX ASCII characters.

# Remote Input Operation

## Validation

Each character is validated for parity, framing, overrun, and break interrupt errors. If an error is detected, an error message is displayed to indicate the type of error. For overrun errors, an error record is transmitted back to the remote. For parity and framing errors, no error record is transmitted since any transmission most likely will result in a similar error at the remote and the record would be unintelligible. If a spurious character is received, an error message is flashed on the LCD. When a complete input record is received, the record is validated and processed. If the record is invalid, an error record is transmitted back to the remote device. All input records are validated in the following manner:

- must begin with a “:”, and end with a carriage return, line feed sequence,
- must contain all valid ASCII characters,
- must contain a valid record type,
- must contain a valid function code, and
- must contain a valid function subcode when required.

## Acknowledgment

The GSI 61 will acknowledge the correct reception and processing of all input records by transmitting an ASCII ACK character after the record has been processed. This record acknowledgment will not be sent if the GSI 16 compatible record format has been selected.

## Input Record Type

These records are sent by the remote device to control its functions.

### Input Record Type 1 to 4

Reserved for the GSI 10.

### Input Record Type 5 - Pushbutton Code Record

This record type provides the ability to remotely simulate the operation of all user controls. The record specifies the control operation using a function code which defines the group of controls and a sub-function code which defines the specific parameter to select of the function to perform. Control operations are processed in the same manner as if they had been manually entered. All parameter or functional defaults and restrictions will still apply.

Function Code	Function Group	Function Subgroup	Sub Code Pushbutton/ Function
01	Reserved for GSI 10		
02	Channel 1 Stimulus	“0” “1” “2” “3” “4” “5” “6”	Tone NB Noise White Noise Speech Noise Mic Ext A Ext B
03	Reserved for GSI 10		
04	Reserved for GSI 10		
05	Channel 2 Stimulus	“0” “1” “2” “3” “4” “5” “6”	Tone NB Noise White Noise Speech Noise Mic Ext A Ext B
06	Transducer Combinations	“0” “1” “2” “3” “4” “5” “6” “7” “8” “9” “A” “B” “C” “D” “E” “F”	<u>Channel 1</u> <u>Channel 2</u> Bone   Bone Spk   Spk Spk   Phone Bone   Phone Phone   Phone Phone   Bone Phone   Spk Phone   Insert Bone   Spk Bone   Insert Spk   Bone Spk   Insert Insert   Phone Insert   Bone Insert   Spk Insert   Insert
07	Output Routing Combinations	“0” “1” “2” “3” “4”	<u>Channel 1</u> <u>Channel 2</u> Left   Right Right   Left Left   Left Right   Right Left/Right   Left/Right
08	Subject Trigger	“0” “1”	No Yes
09	FM	“0” “1”	Off On
10	Interlock	“0” “1”	Off On
11	Tracking	“0” “1”	Off On

Function Code	Function Group	Function Subgroup	Sub Code Pushbutton/ Function
12	Reserved for GSI 10		
13	Reserved for GSI 10		
14	Reserved for GSI 10		
15	Reserved for GSI 10		
16	Test Frequency	“0” “1”	Decrement Frequency Increment Frequency
17	Reserved for GSI 10		
18	Channel 1 Tone Bar	“0” “1”	Release Press
19	Channel 2 Tone Bar	“0” “1”	Release Press
20	Channel 1 Intensity Control	“0” “1”	Decrease 1 step Increase 1 step
21	Channel 2 Intensity Control	“0” “1”	Decrease 1 step Increase 1 step
22	Channel 1 Interrupt	“0” “1”	Off On
23	Channel 2 Interrupt	“0” “1”	Off On
24	Reserved for GSI 10		
25	Remote Output Request	“0”  “1”	Normal mode: Initiates a data record transfer of the current type selected on the remote dip switches.  HL Calibration Mode: Stores the calibration data into EEPROM.  All modes: Initiates a data record transfer of the current test type selected on the remote dip switches.
26	Pulsed	“0” “1”	Off On
27	ALternate	“0” “1”	Off On
28	SISI	“0” “1”	Off On
29	Transducer Type	“0” “1”	Ch 1 Phone Ch 1 Bone

Function Code	Function Group	Function Subgroup	Sub Code Pushbutton/ Function
29 continued	Transducer Type	“2” “3” “4” “5” “6” “7”	Ch 1 Spk Ch 1 Insert Ch 2 Phone Ch 2 Bone Ch 2 Spk Ch 2 Insert
30	Routing	“0” “1” “2” “3” “4” “5”	Ch 1 Left Ch 1 Right Ch 1 Left/Right Ch 2 Left Ch 2 Right Ch 2 Left/Right
31	SISI/ HL Control Step Size	“0” “1” “2”	dB dB dB
32	Monitor Speaker	“0” “1”	Off On
33	Calibration Mode	“0” “1”	Exit to Normal Mode Enter HL Calibration Mode
34	Scorer/Timer	“0” “1” “2”	Correct/Start Clear/Clear Incorrect/Stop
35	Print	“0”	
36	Data Erase	“0”	
37	Talk Forward	“0” “1”	Off On
38	Talk Forward Level	“0” “1” “2” “3”	45 dB 60 dB 75 dB 90 dB
39	Oscillator Control	“0” “1”	Turn Oscillator off Turn Oscillator on
40	Screen Display	“0” “1” “2”	Status display Audiogram display High Freq. Audiogram Display
41	Save	“0”	
42	Frequency range	“0” “1”	High Freq. (8000 - 20000 Hz) Normal Freq. (125 - 12000 Hz)
43	Transmit Unit ID record	“0”	

Function Code	Function Group	Function Subgroup	Sub Code Pushbutton/ Function
44	Transmit Unit configuration record	“0”	
45	Load Default Data	“0” “1” “2”	Load HL configuration default data Load Self Calibration default data Load all default data
46	Perform Self-Cal	“0”	
47	Data Transfer	“0” “1” “2” “3”	Transmit a data output record in the following format: (Spare format, currently defaults to “3”) GSI 16 Compatible Short Data Record GSI 61 Short Data Record Test Battery Data Record
48	Enter Diagnostic Mode	“0” “1” “2” “3” “4”	Exit to Normal Mode Enter Push Button diagnostic Enter Display diagnostic Enter Hardware diagnostic Enter Loopback diagnostic

Input Record  
Type 6- Set Test  
Frequency Record

This record is used to set the frequency of the oscillator to the standard audiometric low and high frequencies in the Normal, HL Calibration and SISI Calibration modes. This record type is invalid in the Push Button diagnostic, Display diagnostic and Loopback diagnostic modes. Nonstandard frequencies, frequencies outside the current range or frequencies invalid for the current transducer are invalid and will result in an error record being transmitted. Frequencies greater than 12 kHz are invalid if the GSI 16 compatible record format is selected and will also result in an error record being transmitted.

Character Offset	Number of Characters	Field Name	Field Description
0	1	Record Prefix	“:”
1	1	Record Type	“6”
2	2	Function Code	“01”
4	5	Test Frequency	Format: Frequency value in Hz ( i.e. 750 Hz = “_750”) Range: Low Freq. - 125 Hz to 12 kHz High Freq. - 8 K to 20 kHz Resolution: Standard Audio frequencies
9	2	Record Terminator	“CR”, “LF”

**Input Record  
Type 7 - Set HL Record**

The record which is set by this record varies based on the operating mode indicated below. This record type is invalid in the Push Button Diagnostic, Display Diagnostic and Loopback Diagnostic modes and will result in an error record being transmitted.

Character Offset	Number of Characters	Field Name	Field Description
0	1	Record Prefix	“:”
1	1	Record Type	“7”
2	2	Function Code	“01” = Ch 1 “02” = Ch 2
4	4	HL value	Format HL value with 1 implied decimal position (i.e. 20 dB HL = “_200”) Range: Low Frequency: -10 to 120 dB HL High Frequency: -20 to 100 dB HL Resolution: 1 dB
8	2	Record Terminator	“CR”, “LF”

## Remote Output Operation

### Output Record Type 1- GSI 16 Compatible Short Data Record

These records are sent by the GSI 61 to the remote computer to transfer parameter or status information. During the time that an output record is being sent and transmitted, the Data Transfer indicator is displayed on the LCD panel. The indication displays for a minimum of 0.5 seconds.

Character Offset	Number of Characters	Field Name	Field Description
0	1	Record Prefix	“:”
1	1	Record Type	“1”
2	1	Test Type	“0” = Tone test “1” =Speech test “3” =SISI test “4” =Alternate test
3	1	Ch 1 Stimulus	“1” =Tone “2” =NB Noise “3” =White Noise “4” =Speech Noise “5” =Mic “6” =Ext A “7” =Ext B
4	1	Zero Field	“0”
5	1	SISI	“0” =None/Off “1” =Reserved for GSI 10 “2” =On with 1 dB step size “3” =On with 2 dB step size

Character Offset	Number of Characters	Field Name	Field Description																																		
5 continued	1	SISI	“4” =Reserved for GSI 10 “5” =On with 5 dB step size																																		
6	1	Timing	“0” =None/Steady “1” =Reserved for the GSI 10 “2” =Pulsed 200/200 msec on/off																																		
7	2	Zero Field	“00”																																		
9	1	Ch 2 Stimulus	“1” =Tone “2” =NB Noise “3” =White Noise “4” =Speech Noise “5” =Mic “6” =Ext A “7” =Ext B																																		
10	1	Transducer Type	<table border="0"> <thead> <tr> <th><u>Ch 1</u></th> <th><u>Ch 2</u></th> </tr> </thead> <tbody> <tr><td>“1” =Bone</td><td>Bone</td></tr> <tr><td>“2” =Spk</td><td>Spk</td></tr> <tr><td>“3” =Spk</td><td>Phone</td></tr> <tr><td>“4” =Bone</td><td>Phone</td></tr> <tr><td>“5” =Phone</td><td>Phone</td></tr> <tr><td>“6” =Bone</td><td>Spk</td></tr> <tr><td>“7” =Bone</td><td>Insert</td></tr> <tr><td>“8” =Spk</td><td>Bone</td></tr> <tr><td>“9” =Spk</td><td>Insert</td></tr> <tr><td>“A” =Phone</td><td>Bone</td></tr> <tr><td>“B” =Phone</td><td>Spk</td></tr> <tr><td>“C” =Phone</td><td>Insert</td></tr> <tr><td>“D” =Insert</td><td>Bone</td></tr> <tr><td>“E” =Insert</td><td>Spk</td></tr> <tr><td>“F” =Insert</td><td>Phone</td></tr> <tr><td>“G” =Insert</td><td>Insert</td></tr> </tbody> </table>	<u>Ch 1</u>	<u>Ch 2</u>	“1” =Bone	Bone	“2” =Spk	Spk	“3” =Spk	Phone	“4” =Bone	Phone	“5” =Phone	Phone	“6” =Bone	Spk	“7” =Bone	Insert	“8” =Spk	Bone	“9” =Spk	Insert	“A” =Phone	Bone	“B” =Phone	Spk	“C” =Phone	Insert	“D” =Insert	Bone	“E” =Insert	Spk	“F” =Insert	Phone	“G” =Insert	Insert
<u>Ch 1</u>	<u>Ch 2</u>																																				
“1” =Bone	Bone																																				
“2” =Spk	Spk																																				
“3” =Spk	Phone																																				
“4” =Bone	Phone																																				
“5” =Phone	Phone																																				
“6” =Bone	Spk																																				
“7” =Bone	Insert																																				
“8” =Spk	Bone																																				
“9” =Spk	Insert																																				
“A” =Phone	Bone																																				
“B” =Phone	Spk																																				
“C” =Phone	Insert																																				
“D” =Insert	Bone																																				
“E” =Insert	Spk																																				
“F” =Insert	Phone																																				
“G” =Insert	Insert																																				
11	1	Output Routing	<table border="0"> <thead> <tr> <th><u>Ch1</u></th> <th><u>Ch2</u></th> </tr> </thead> <tbody> <tr><td>“0” =None</td><td>None</td></tr> <tr><td>“1” =Left</td><td>Right</td></tr> <tr><td>“2” =Right</td><td>Left</td></tr> <tr><td>“3” =Left</td><td>Left</td></tr> <tr><td>“4” =Right</td><td>Right</td></tr> <tr><td>“5” =LR</td><td>LR</td></tr> <tr><td>“6” =Left</td><td>LR</td></tr> <tr><td>“7” =Right</td><td>LR</td></tr> <tr><td>“8” =LR</td><td>Left</td></tr> <tr><td>“9” =LR</td><td>Right</td></tr> <tr><td>“A” =None</td><td>Left</td></tr> <tr><td>“B” =None</td><td>Right</td></tr> <tr><td>“C” =Left</td><td>None</td></tr> <tr><td>“D” =Right</td><td>None</td></tr> </tbody> </table>	<u>Ch1</u>	<u>Ch2</u>	“0” =None	None	“1” =Left	Right	“2” =Right	Left	“3” =Left	Left	“4” =Right	Right	“5” =LR	LR	“6” =Left	LR	“7” =Right	LR	“8” =LR	Left	“9” =LR	Right	“A” =None	Left	“B” =None	Right	“C” =Left	None	“D” =Right	None				
<u>Ch1</u>	<u>Ch2</u>																																				
“0” =None	None																																				
“1” =Left	Right																																				
“2” =Right	Left																																				
“3” =Left	Left																																				
“4” =Right	Right																																				
“5” =LR	LR																																				
“6” =Left	LR																																				
“7” =Right	LR																																				
“8” =LR	Left																																				
“9” =LR	Right																																				
“A” =None	Left																																				
“B” =None	Right																																				
“C” =Left	None																																				
“D” =Right	None																																				
12	1	Subject Response	“0” =Released “1” =Pressed																																		
13	1	FM	“0” = Off “1” = On																																		
14	1	Interlock	“0” = Off “1” = On																																		

Character Offset	Number of Characters	Field Name	Field Description
15	1	Tracking	“0” = Off “1” = On
16	2	Zero Field	“00”
18	1	HL Step Size	“1” = 1 dB “2” = Reserved for GSI 10 “3” = 5 dB “4” = 2 dB
19	4	Ch 1 Numeric HL Display Data	“-100” to “1200” Range: -10.0 to 120.0 dB
23	1	Ch 1 Interrupt	“0” = Off “1” = On
24	4	Ch 2 Numeric HL Display Data	“-100” to “1200” Range: - 10.0 to 120.0 dB
28	1	Ch 2 Interrupt	“0” = Off “1” = On
29	5	Frequency Display Data	“_125” to “12000” Range: 125 to 12000 Hz in standard audiometric frequencies
4	6	Zero Field	“000000”
40	2	Checksum	See page 6-4; Checksums
42	2	Record Terminator	“CR”, “LF”

### Output Record Type 4 - Error Record

Contains information on the type of error which has occurred. The types of errors which would result in an Error Record are:

- System errors
- Input record which has an incorrect format or is invalid for the current operating mode
- Pushbutton operation commands which are invalid

Character Offset	Number of Characters	Field Name	Field Description
0	1	Record Prefix	“:”
1	1	Record Type	“4”
2	2	Error Code	See next table; Error Codes
4	2	Checksum	See page 6-4; Checksums
6	2	Record Terminator	“CR”, “LF”

**Error Record Codes**

Error Code	Error Description
01	Invalid ASCII character in an input record
02	Invalid number of characters in an input record
03	Invalid input record type
04	Invalid input record function code
05	Invalid input record function sub code
06	Reserved
07	Invalid Set Frequency record Frequency value
08	Invalid Set HL record HL value
09	Invalid machine conditions for GSI61 compatible data
10	Generic NACK in response to an invalid input record
11	Invalid Start-of Record: when receiving unexpected characters
12	Overrun of GSI61 UART
13	Invalid combination of Basic Speakers and Booster Amp
14	Invalid HL; requested HL cannot be provided due to attenuator limits. HL set to closest possible value.
15	Printing was aborted by keypad.
16	Printing was unsuccessful due to communications or printer problem.

**Output Record  
Type 5 - GSI61 Short  
Data Record**

Contains the current state of all instrument parameters, including the expanded frequency and HL ranges of the GSI61. This record is not GSI 16 compatible.

Character Offset	Number of Characters	Field Name	Field Description
0	1	Record Prefix	“:”
1	1	Record Type	“5”
2	1	Test Type	“0” = Tone test “1” = Speech test “2” = SISI test “3” = Alternate test
3	1	Ch 1 Stimulus	“1” = Tone “2” = NB Noise “3” = White Noise “4” = Speech Noise “5” = Mic “6” = Ext A “7” = Ext B
4	1	Zero Field	“0”
5	1	SISI	“0” = None/Off “1” = Reserved for GSI 10 “2” =On with 1 dB step size “3” =On with 2 dB step size “4” = Reserved for GSI 10 “5” =On with 5 dB step size
6	1	Timing	“0” = None/Steady “1” = Reserved for the GSI 10 “2” =Pulsed 200/200 msec on/off
7	2	Zero Field	“00”

Character Offset	Number of Characters	Field Name	Field Description																																		
9	1	Ch 2 Stimulus	"1" = Tone "2" = NB Noise "3" = White Noise "4" = Speech Noise "5" = Mic "6" = Ext A "7" = Ext B																																		
10	1	Transducer Type	<table border="0"> <thead> <tr> <th><u>Ch 1</u></th> <th><u>Ch 2</u></th> </tr> </thead> <tbody> <tr><td>"1" = Bone</td><td>Bone</td></tr> <tr><td>"2" = Spk</td><td>Spk</td></tr> <tr><td>"3" = Spk</td><td>Phone</td></tr> <tr><td>"4" = Bone</td><td>Phone</td></tr> <tr><td>"5" = Phone</td><td>Phone</td></tr> <tr><td>"6" = Bone</td><td>Spk</td></tr> <tr><td>"7" = Bone</td><td>Insert</td></tr> <tr><td>"8" = Spk</td><td>Bone</td></tr> <tr><td>"9" = Spk</td><td>Insert</td></tr> <tr><td>"A" = Phone</td><td>Bone</td></tr> <tr><td>"B" = Phone</td><td>Spk</td></tr> <tr><td>"C" = Phone</td><td>Insert</td></tr> <tr><td>"D" = Insert</td><td>Bone</td></tr> <tr><td>"E" = Insert</td><td>Spk</td></tr> <tr><td>"F" = Insert</td><td>Phone</td></tr> <tr><td>"G" = Insert</td><td>Insert</td></tr> </tbody> </table>	<u>Ch 1</u>	<u>Ch 2</u>	"1" = Bone	Bone	"2" = Spk	Spk	"3" = Spk	Phone	"4" = Bone	Phone	"5" = Phone	Phone	"6" = Bone	Spk	"7" = Bone	Insert	"8" = Spk	Bone	"9" = Spk	Insert	"A" = Phone	Bone	"B" = Phone	Spk	"C" = Phone	Insert	"D" = Insert	Bone	"E" = Insert	Spk	"F" = Insert	Phone	"G" = Insert	Insert
<u>Ch 1</u>	<u>Ch 2</u>																																				
"1" = Bone	Bone																																				
"2" = Spk	Spk																																				
"3" = Spk	Phone																																				
"4" = Bone	Phone																																				
"5" = Phone	Phone																																				
"6" = Bone	Spk																																				
"7" = Bone	Insert																																				
"8" = Spk	Bone																																				
"9" = Spk	Insert																																				
"A" = Phone	Bone																																				
"B" = Phone	Spk																																				
"C" = Phone	Insert																																				
"D" = Insert	Bone																																				
"E" = Insert	Spk																																				
"F" = Insert	Phone																																				
"G" = Insert	Insert																																				
11	1	Output Routing	<table border="0"> <thead> <tr> <th><u>Ch1</u></th> <th><u>Ch2</u></th> </tr> </thead> <tbody> <tr><td>"0" =None</td><td>None</td></tr> <tr><td>"1" =Left</td><td>Right</td></tr> <tr><td>"2" =Right</td><td>Left</td></tr> <tr><td>"3" =Left</td><td>Left</td></tr> <tr><td>"4" =Right</td><td>Right</td></tr> <tr><td>"5" =LR</td><td>LR</td></tr> <tr><td>"6" =Left</td><td>LR</td></tr> <tr><td>"7" =Right</td><td>LR</td></tr> <tr><td>"8" =LR</td><td>Left</td></tr> <tr><td>"9" =LR</td><td>Right</td></tr> <tr><td>"A" =None</td><td>Left</td></tr> <tr><td>"B" =None</td><td>Right</td></tr> <tr><td>"C" =Left</td><td>None</td></tr> <tr><td>"D" =Right</td><td>None</td></tr> </tbody> </table>	<u>Ch1</u>	<u>Ch2</u>	"0" =None	None	"1" =Left	Right	"2" =Right	Left	"3" =Left	Left	"4" =Right	Right	"5" =LR	LR	"6" =Left	LR	"7" =Right	LR	"8" =LR	Left	"9" =LR	Right	"A" =None	Left	"B" =None	Right	"C" =Left	None	"D" =Right	None				
<u>Ch1</u>	<u>Ch2</u>																																				
"0" =None	None																																				
"1" =Left	Right																																				
"2" =Right	Left																																				
"3" =Left	Left																																				
"4" =Right	Right																																				
"5" =LR	LR																																				
"6" =Left	LR																																				
"7" =Right	LR																																				
"8" =LR	Left																																				
"9" =LR	Right																																				
"A" =None	Left																																				
"B" =None	Right																																				
"C" =Left	None																																				
"D" =Right	None																																				
12	1	Subject Response	"0" = Released "1" = Pressed																																		
13	1	FM	"0" = Off "1" = On																																		
14	1	Interlock	"0" = Off "1" = On																																		
15	1	Tracking	"0" = Off "1" = On																																		
16	2	Zero Field	"00"																																		
18	1	HL Step Size	"1" = 1 dB "2" = Reserved for GSI 10 "3" = 5 dB "4" = 2 dB																																		

Character Offset	Number of Characters	Field Name	Field Description
19	4	Ch 1 Numeric HL Display Data	“-200” to “1000” Range: -20.0 to 100.0 dB
23	1	Ch 1 Interrupt	“0” = Off “1” = On
24	4	Ch 2 Numeric HL Display Data	“-200” to “1000” Range: - 20. 0 to 100.0 dB
28	1	Ch 2 Interrupt	“0” = Off “1” = On
29	5	Frequency Display Data	“_125” to “20000” Range: 125 to 20000 Hz in standard audiometric frequencies
34	5	Timer Value	Elapsed time in seconds. Range: “_000” to “12000” seconds
39	3	Scorer # Correct	Number of correct Speech Test Value Zero responses. Range: “_00” to “100”
42	3	Scorer Total Value	Total number of Speech Test presentations. Range: “_00” to “100”
45	2	Checksum	See page 6-4; Checksums
47	2	Record Terminator	“CR”, “LF”

Contains all left and right ear test data currently stored in the test data memory. This record is not GSI 16 compatible.

**Output Record  
Type 6 - Test Battery  
Data Record**

Character Offset	Number of Characters	Data Type	Field Name	Field Description
0	1	ASCII	Record Prefix	“:”
1	1	ASCII	Record Type	“6”

**Record Prefix**

**Left Ear Test Data - Pure  
Tone**

2	4	slnt	Pure Tone Test - 125 Hz Air Conduction Threshold- Test Ear	-20 to 120 dB x 2 NR = 260 to 540 NT =32768 (0x8000)
6	4	slnt	Pure Tone Test - 125 Hz Air Conduction Threshold- Masking Ear	-20 to 120 dB x 2 NR = 260 to 540 NT = 32768 (0x8000)

Character Offset	Number of Characters	Data Type	Field Name	Field Description
10	4	slnt	Pure Tone Test - 125 Hz Bone Conduction Threshold- Test Ear	-20 to 120 NR = 260 to 540 NT = 32768 (0x8000)
14	4	slnt	Pure Tone Test - 125 Hz Bone Conduction Threshold- Masking Ear	-20 to 120 dB x 2 NR = 260 to 540 NT = 32768 (0x8000)
18	4	slnt	Pure Tone Test - 125 Hz Sound Field	-20 to 120 dB x 2 NR = 260 to 540 NT = 32768 (0x8000)
22	20		Pure Tone Test - 250 Hz	See Pure Tone Test - 125 Hz fields
42	20		Pure Tone Test - 500 Hz	See Pure Tone Test - 125 Hz fields
62	20		Pure Tone Test - 750 Hz	See Pure Tone Test - 125 Hz fields
82	20		Pure Tone Test - 1 kHz	See Pure Tone Test - 125 Hz fields
102	20		Pure Tone Test - 1.5 kHz	See Pure Tone Test - 125 Hz fields
122	20		Pure Tone Test - 2 kHz	See Pure Tone Test - 125 Hz fields
142	20		Pure Tone Test - 3 kHz	See Pure Tone Test - 125 Hz fields
162	20		Pure Tone Test - 4 kHz	See Pure Tone Test - 125 Hz fields
182	20		Pure Tone Test - 6 kHz	See Pure Tone Test - 125 Hz fields
202	20		Pure Tone Test - 8 kHz Low Freq	See Pure Tone Test - 125 Hz fields
222	20		Pure Tone Test - 12 kHz	See Pure Tone Test - 125 Hz fields
242	20		Pure Tone Test - 8 kHz High Freq	See Pure Tone Test - 125 Hz fields
262	20		Pure Tone Test - 9 kHz	See Pure Tone Test - 125 Hz fields
282	20		Pure Tone Test - 10 kHz	See Pure Tone Test - 125 Hz fields
302	20		Pure Tone Test - 11.2 kHz	See Pure Tone Test - 125 Hz fields

Character Offset	Number of Characters	Data Type	Field Name	Field Description
322	20		Pure Tone Test - 12.5 kHz	See Pure Tone Test - 125 Hz fields
342	20		Pure Tone Test - 14 kHz	See Pure Tone Test - 125 Hz fields
362	20		Pure Tone Test - 16 kHz	See Pure Tone Test - 125 Hz fields
382	20		Pure Tone Test - 18 kHz	See Pure Tone Test - 125 Hz fields
402	20		Pure Tone Test - 20 kHz	See Pure Tone Test - 125 Hz fields
422	2	uChar	Bone Vibrator Calibration	“_0” = Forehead “_1” = Mastoid

**Speech Test**

424	4	slnt	Speech Test - Test Ear Threshold	-20 to 120 dB x 2 NR = 260 to 540 NT= 32768 (0x8000)
428	4	slnt	Speech Test - Masking Ear Threshold	-20 to 120 dB x 2 NR = 260 to 540 NT = 32768 (0x8000)
432	2	uChar	Speech Test - Masking Type	“_0” = None “_1” = White Noise “_2” = Speech Noise “_3” = Ext A “_4” = Ext B
434	2	uChar	Speech Test - Number Presented	_0 to 100
436	2	uChar	Speech Test - Number Correct	_0 to 100

**SISI Test**

438	4	slnt	SISI Test - 125 Hz Test Ear Threshold	_-20 to 120 dB HL x 2 NR = 260 to 540 NT = 32768 (0x8000)
442	2	uChar	SISI Test - 125 Hz Pulse Height	“_0” = 5 dB “_1” = 2 dB “_2” = 1 dB
444	2	uChar	SISI Test - 125 Hz Number Presented	_0 to 100
446	2	uChar	SISI Test - 125 Hz Number Correct	_0 to 100
448	10		SISI Test - 250 Hz	See SISI Test - 125 Hz Fields

Character Offset	Number of Characters	Data Type	Field Name	Field Description
458	10		SISI Test - 500 Hz	See SISI Test - 125 Hz Fields
468	10		SISI Test - 750 Hz	See SISI Test - 125 Hz Fields
478	10		SISI Test - 1 kHz	See SISI Test - 125 Hz Fields
488	10		SISI Test - 1.5 kHz	See SISI Test - 125 Hz Fields
498	10		SISI Test - 2 kHz	See SISI Test - 125 Hz Fields
508	10		SISI Test - 3 kHz	See SISI Test - 125 Hz Fields
518	10		SISI Test - 4 kHz	See SISI Test - 125 Hz Fields
528	10		SISI Test - 6 kHz	See SISI Test - 125 Hz Fields
538	10		SISI Test - 8 kHz Low Frequency	See SISI Test - 125 Hz Fields
548	10		SISI Test - 12 kHz	See SISI Test - 125 Hz Fields
558	10		SISI Test - 8 kHz High Frequency	See SISI Test - 125 Hz Fields
568	10		SISI Test - 9 kHz	See SISI Test - 125 Hz Fields
578	10		SISI Test - 10 kHz	See SISI Test - 125 Hz Fields
588	10		SISI Test - 11.2 kHz	See SISI Test - 125 Hz Fields
598	10		SISI Test - 12.5 kHz	See SISI Test - 125 Hz Fields
608	10		SISI Test - 14 kHz	See SISI Test - 125 Hz Fields
618	10		SISI Test - 16 kHz	See SISI Test - 125 Hz Fields
628	10		SISI Test - 18 kHz	See SISI Test - 125 Hz Fields
638	10		SISI Test - 20 kHz	See SISI Test - 125 Hz Fields

## Alternate (ABLB)

Character Offset	Number of Characters	Data Type	Field Name	Field Description
648	4	slnt	Alternate Test - 125 Hz Test Ear Threshold	-20 to 120 dB x 2 NR = 260 to 540 NT = 32768 (0x8000)
652	4	slnt	Alternate Test - 125 Hz Masking Ear Threshold	-20 to 120 dB x 2 NR = 260 to 540 NT = 32768 (0x8000)
656	8		Alternate Test - 250 Hz	See Alternate Test - 125 Hz fields
664	8		Alternate Test - 500 Hz	See Alternate Test - 125 Hz fields
672	8		Alternate Test - 750 Hz	See Alternate Test - 125 Hz fields
680	8		Alternate Test - 1 kHz	See Alternate Test - 125 Hz fields
688	8		Alternate Test - 1.5 kHz	See Alternate Test - 125 Hz fields
696	8		Alternate Test - 2 kHz	See Alternate Test - 125 Hz fields
704	8		Alternate Test - 3 kHz	See Alternate Test - 125 Hz fields
712	8		Alternate Test - 4 kHz	See Alternate Test - 125 Hz fields
720	8		Alternate Test - 6 kHz	See Alternate Test - 125 Hz fields
728	8		Alternate Test - 8 kHz Low Frequency	See Alternate Test - 125 Hz fields
736	8		Alternate Test - 12 kHz	See Alternate Test - 125 Hz fields
744	8		Alternate Test - 8 kHz High Frequency	See Alternate Test - 125 Hz fields
752	8		Alternate Test - 9 kHz	See Alternate Test - 125 Hz fields
760	8		Alternate Test - 10 kHz	See Alternate Test - 125 Hz fields
768	8		Alternate Test - 11.2 kHz	See Alternate Test - 125 Hz fields
776	8		Alternate Test - 12.5 kHz	See Alternate Test - 125 Hz fields

Character Offset	Number of Characters	Data Type	Field Name	Field Description
784	8		Alternate Test - 14 kHz	See Alternate Test - 125 Hz fields
792	8		Alternate Test - 16 kHz	See Alternate Test - 125 Hz fields
800	8		Alternate Test - 18 kHz	See Alternate Test - 125 Hz fields
808	8		Alternate Test - 20 kHz	See Alternate Test - 125 Hz fields

**Right Ear Test Data**

816	814			See Left Ear fields
-----	-----	--	--	---------------------

**Record Terminator**

1630	2	uChar	Checksum	See page 6-4; Checksums
1632	2	ASCII	Record Terminator	“CR”, “LF”

**Note:** HL threshold values are transmitted as hexadecimal values scaled by 2.

**Output Record  
Type 7 - Instrument  
Type**

Contains the instrument type and software version information. This record is not GSI 16 compatible.

Character Offset	Number of Characters	Field Name	Field Description
0	1	Record Prefix	“:”
1	1	Record Type	“7”
2	2	Instrument Type	“04”
4	5	Software Revision	“xx.xx”
9	2	Checksum	See page 6-4; Checksums
11	2	Record Terminator	“CR”, “LF”

**Output Record  
Type 8 - Unit  
Configuration Record**

Contains the information on Dip Switch configuration selections. This record is not GSI 16 compatible.

Character Offset	Number of Characters	Field Name	Field Description
0	1	Record Prefix	“.”
1	1	Record Type	“8”
2	1	NBN Offset	“0” = Custom Narrow Band Noise offsets in use “1” = Standard Narrow Band Noise offsets in use
3	1	WN Offsets	“0” = Custom White Noise offsets in use “1” = Standard White Noise offsets in use
4	1	Insert Phone Type	“0” = Paired EARTone “1” = single insert phone in use
5	1	Speaker Type	“0” = Basic “1” = High Performance
6	1	Booster Amp	“0” = Not in use “1” = Booster Amp in use
7	1	Bone Vibrator Calibration	“0” = Forehead “1” = Mastoid
8	1	Speech Filter	“0” = Not in use “1” = Speech filter on use
9	1	Language	“0” = English “1” = French “2” = German “3” = Italian “4” = Spanish
10	1	High Frequency Phone Type	“0” = Other “1” = Sennheiser
11	1	Phone Coupler Type	“0” = NBS 9A “1” = IEC 318
12	1	Insert Phone Coupler Type	“0” = IEC 126 (HA1/HA2) “1” = IEC 711
13	1	Speaker Azimuth Calibration	“0” = 0 degrees “1” = 45 degrees
14	1	High Frequency Option	“0” = installed “1” = Not installed
15	1	Speech Calibration	“0” = Custom “1” = Standard
16	2	Checksum	See page 6-4; Checksums
18	2	Record Terminator	“CR”, “LF”

# Warnings, Cautions and Errors



## Warnings

The GSI 61 Clinical Audiometer is designed to be used with a hospital grade outlet. Injury to personnel or damage to equipment can result when a three-prong or two-prong adaptor is connected between the GSI 61 power plug and an AC outlet or extension cord.

Audiometers which bear the Underwriters Laboratories, Inc. label should be interconnected with accessories that have the proper electrical compatibility and are listed as meeting the requirements of the UL Medical and Dental Equipment Standard. Connection of accessories not meeting these requirements may result in electrical leakage currents in excess of those allowed by the standard and present a potential electrical shock hazard to the person being tested.

This warning icon found on the back of the LCD panel indicates dangerous voltage within the panel. Access to the LCD panel is limited to authorized Grason-Stadler service representatives.



When testing with the High Frequency earphones, do not allow the presentation of the signal at the maximum dB HL to exceed 10 minutes. The buildup of increased temperature can cause harm to the earphones.

This caution label refers the user to the accompanying literature and manuals.

## Cautions



This icon indicates that the GSI 61 is in compliance with Class 1, Type B requirements of IEC 601-1.



The following is the list of status messages which will occur with operation of the GSI 61 Audiometer. These messages will be displayed in one of the bottom three message areas.

## Status Messages

<b>Using Default Data</b>	Indicates that the selected transducer and stimulus are not calibrated to standard specified (ANSI/ISO) levels.
<b>Erasing Data</b>	Indicates that the GSI 61 is clearing stored test information.
<b>Saving Data</b>	Indicates that the test information is being saved into memory.
<b>No Test Data Stored</b>	Indicates that there is no test data available to be erased or printed.
<b>Check Hi-Freq Cables</b>	Indicates that the High Frequency function is enabled but the cables plugged into the L&R phone jacks are <i>not</i> the GSI-specified type.
<b>Invalid Selection</b>	Indicates that an incorrect selection, such as incompatible transducers, has been made.
<b>Not Available</b>	Indicates an uninstalled option has been selected.
<b>No Test Data Stored</b>	Indicates that there is no data available for printing, although the Print Audiogram button has been pressed.
<b>Data Transfer</b>	Indicates that data has been processed either by the printer or by a remote computer.
<b>Check Printer</b>	A check is done to see if the printer is connected and ready to receive data by checking the hardware flow control line. If printer is not ready this message will be flashed.
<b>Printing</b>	This is an informational message which is displayed while outputting data to the printer. It appears on the lower right section of the LCD.
<b>No Printer Response</b>	If communications problems occur during the course of printing, this error message will be flashed.

## Communications Error Messages

The following communication errors may occur during data transmission through the RS 232 communications:

<b>Comm error:</b>	<b>parity</b>	Check GSI 61 and PC parity settings.
<b>Comm error:</b>	<b>framing</b>	Check GSI 61 and PC selections for number of stop bits and number of bits per command.
<b>Comm error:</b>	<b>overrun</b>	See 'framing'.
<b>Comm error:</b>	<b>multiple</b>	Check parity, baud rate, number of stop bits and byte size on GSI 61.
<b>Comm error:</b>	<b>spurious</b>	Soft error. Should not be repeatable; if so, problem could be anywhere in GSI 61 digital circuits or PC's communication circuits.
<b>Comm error:</b>	<b>break</b>	See 'spurious'.

If the word "Help" followed by an error code is displayed, note the Help Code number. See the GSI 61 Service Manual (1761-0110) for detailed descriptions of these. Turn off the power to the GSI 61 and wait 30 seconds. Restart the instrument. Often the error will be cleared by this action. If the error persists, contact your authorized Grason-Stadler service representative.

# Bibliography

---

- American National Standards Specifications for Audiometers (ANSI Standard S3.6-1989).
- American National Standards Specifications for Calibration of Pure Tone Bone Conduction Audiometers (ANSI Standard S3.43-1992).
- Acoustics - Standard Reference Zero for Calibration of Pure Tone Audiometers (ISO Standard 389-1975).
- Audiometers - International Electrochemical Commission (IEC 645 - 1992, 1993).
- Criteria for Permissible Ambient Noise During Audiometric Testing (ANSI Standard S3.1 - 1977).
- Dempsey, James J., 6000 Hz as an Early Indicator of Noise-Induced Hearing Loss, "Ear and Hearing", Vol. 6, No. 3, 1985, pp. 159-160.
- Dirks, Donald D., et al, Bone Conduction Calibration: Current Status, "Journal of Speech and Hearing Disorders", XLIV, May 1979, pp. 143-155.
- Dreschler, W.A. et al, Role of High-Frequency Audiometry in Early Detection of Ototoxicity, "Audiology" (1989) 28 (4): 211-20.
- Frank, T., High Frequency Hearing Thresholds in Young Adults Using a Commercially Available Audiometer, "Ear and Hearing", Vol. 11, No. 6, 1990, pp. 450-454.
- Grimes, Charles T., Audiologic Evaluation in Infancy and Childhood, "Pediatric Annals", 14:3 March 1985, pp. 211-219.
- Guidelines for Pure-Tone Threshold Audiometry (ASHA 19 - 1989).
- Katz, Jack, *Handbook for Clinical Audiometry* (3rd Edition), Baltimore: Williams and Wilkins (1985).
- Laurell, G. and Jungnelius, U., High-Dose Cisplatin Treatment: Hearing Loss and Plasma Concentrations, "Laryngoscope", 1990 July, 100 (7), pp. 725-34.
- McRorie, T.I. et al, Aminoglycoside Ototoxicity in Cystic Fibrosis, "Am J Dis Child", 1989 Nov, 143 (11): 1328-32.
- Margolis, Robert H., et al, Masking with Narrow-Band FM Noise, "J. Acoust. Soc. Am.", Vol. 56, No. 2, August 1974, pp. 692-694.
- Martin, Frederic N., et al, The Present Status of Audiometric Practice: A Follow-Up Study, "ASHA", July 1978, pp. 531-541.
- Methods for Manual Pure - Tone Threshold Audiometry (ANSI S3.21 - 1978).
- Meyerhoff, W.L., et al, Audiologic Threshold Monitoring of Patients Receiving Ototoxic Drugs, "Ann. Otol. Rhinol. Laryngol.", 1989 Dec 98: 950-54.
- Michael, Paul L., et al, A Comparison of Acoustic Performance Between a New One-piece Earphone Cushion and the Conventional Two-piece MX- 41/AR Cushion, "J. Acoust. Soc. Am.", 67(2), Feb. 1980.

Morgan, Donald E., et al, Suggested Threshold Sound Pressure Levels for Frequency-Modulated (Warble) Tones in the Sound Field, "J. Speech and Hearing Disorders" XLIV, Feb. 1979, pp. 37-54.

Reference Equivalent Threshold Force Levels for Audiometric Bone Vibrators (ANSI Standard S3.26 - 1981).

Royster, Julia D., Audiometric Evaluations for Industrial Hearing, "Sound and Vibration," May 1985, pp. 24-29.

Studebaker, Gerald A., Clinical Masking of Air- and Bone-Conducted Stimuli, "J. Speech and Hearing Disorders", Vol. 29, No. 1, Feb. 1964, pp. 23-35.

Swanson, D.J., et al, Erythromycin Ototoxicity: Prospective Assessment With Serum Concentration and Audiograms in a Study of Patients with Pneumonia, Am. J. Med., Jan 1992 (1): 61-8.

Weatherly, R.A., et al, Cis-Platinum Ototoxicity in Children, "Laryngoscope" 101 (9), 1991 Sept: 917-24.

Underwriter's Laboratory Safety Standard (544 - For Medical and Dental Equipment).

## Bibliography for Test Procedures

Beagley, H.A. and Barnard, S., *Manual for Audiometric Techniques*, Oxford University Press, 1982.

Buus, S., Florentine, M., Redden R., The SISI Test, "Audiology," 21, pp. 273 - 293, 365-385, 1982.

Harbert F. And Young, I. M., Threshold Auditory Adaption, "J. Aud. Res." 2, pp. 273-293, 365-385, 1982.

Hattler, K. W. and Shuman, G. I., Efficiency of the Stenger, Doefler-Stewart and Lengthened OFF-Time Bekesy Tests. "Acta Otolaryngol., 72, pp. 262-267, 1971.

Hood, J. D., Loudness Balance Procedure for the Measurement of Recruitment, "Audiology," 16, pp. 215-228, 1977.

Jerger, J. and Jerger, S., A Simplified Tone Decay Test, "Arch. Otolaryngol., 101, pp. 403-407, 1975.

Jerger, J. and Tillman, T., A New Method for the Clinical Determination of Sensorineural Acuity Level (SAL), "Arch. Otolaryngol." Vol. 71, June 1960, pp. 948 -955.

Katz, J., *Handbook of Clinical Audiology*, William and Wilkins, 3rd Edition, 1985.

Katz, J., The SSW Test: An Interim Report, "J. Speech and Hearing Disorders," 33, pp. 132-146, 1968.

Newby, H.A., *Audiology*, Forth Edition, Prentice-Hall, 1979.

Olsen, W. O. and Noffsinger, D., Comparison of One New and Three Old Tests of Auditory Adaption, Arch. Otolaryngol. 99, 1974, pp. 94-99.

Owens, E., Tone Decay in Eighth Nerve and Cochlear Lesions, J. Speech Hear. Disord., 29, 1964, pp. 14-22.

# Appendix 1 - Test Words



This appendix consists of two parts.

**Part One** contains an Alphabetical List of the Spondaic Words Used in Auditory Tests W-1 and W-2 (SRT). W-1 is a constant level recording; W-2 is a descending level recording.

**Part Two** contains the words (PB Word Lists) used in Auditory Test W-22 (Discrimination).

---

## Alphabetical list of the Spondaic Words used in Auditory Tests W-1 and W-2

### Part One

- |               |               |                |                |
|---------------|---------------|----------------|----------------|
| 1. Airplane   | 10. Eardrum   | 19. Iceberg    | 28. Railroad   |
| 2. Armchair   | 11. Farewell  | 20. Inkwell    | 29. Schoolboy  |
| 3. Baseball   | 12. Grandson  | 21. Mousetrap  | 30. Sidewalk   |
| 4. Birthday   | 13. Greyhound | 22. Mushrooms  | 31. Stairway   |
| 5. Cowboy     | 14. Hardware  | 23. Northwest  | 32. Sunset     |
| 6. Daybreak   | 15. Headlight | 24. Oatmeal    | 33. Toothbrush |
| 7. Doormat    | 16. Horseshoe | 25. Padlock    | 34. Whitewash  |
| 8. Drawbridge | 17. Hotdog    | 26. Pancake    | 35. Woodwork   |
| 9. Duckpond   | 18. Hothouse  | 27. Playground | 36. Workshop   |

---

## CID Auditory Test W-22 (PB Word Lists)

### List 1A

### Part Two

- |                |                   |                  |           |
|----------------|-------------------|------------------|-----------|
| 1. An          | 14. Low           | 27. As           | 40. Jam   |
| 2. Yard        | 15. Owl           | 28. Wet          | 41. Poor  |
| 3. Carve       | 16. It            | 29. Chew         | 42. Him   |
| 4. Us          | 17. She           | 30. See (sea)    | 43. Skin  |
| 5. Day         | 18. High          | 31. Deaf         | 44. East  |
| 6. Toe         | 19. There (their) | 32. Them         | 45. Thing |
| 7. Felt        | 20. Earn (urn)    | 33. Give         | 46. Dad   |
| 8. Stove       | 21. Twins         | 34. True         | 47. Up    |
| 9. Hunt        | 22. Could         | 35. Isle (aisle) | 48. Bells |
| 10. Ran        | 23. What          | 36. Or (oar)     | 49. Wire  |
| 11. Knees      | 24. Bathe         | 37. Law          | 50. Ache  |
| 12. Not (knot) | 25. Ace           | 38. Me           |           |
| 13. Mew        | 26. You (ewe)     | 39. None (nun)   |           |

**List 2A**

- |                 |                   |                 |               |
|-----------------|-------------------|-----------------|---------------|
| 1. Yore (your)  | 14. Now           | 27. Young       | 40. Off       |
| 2. Bin (been)   | 15. Jaw           | 28. Cars        | 41. Ill       |
| 3. Way (weight) | 16. One (won)     | 29. Tree        | 42. Rooms     |
| 4. Chest        | 17. Hit           | 30. Dumb        | 43. Ham       |
| 5. Then         | 18. Send          | 31. That        | 44. Star      |
| 6. Ease         | 19. Else          | 32. Die (dye)   | 45. Eat       |
| 7. Smart        | 20. Tare (tear)   | 33. Show        | 46. Thin      |
| 8. Gave         | 21. Does          | 34. Hurt        | 47. Flat      |
| 9. Pew          | 22. To (two, too) | 35. Own         | 48. Well      |
| 10. Ice         | 23. Cap           | 36. Key         | 49. By (buy)  |
| 11. Odd         | 24. With          | 37. Oak         | 50. Ail (ale) |
| 12. Knee        | 25. Air (heir)    | 38. New (knew)  |               |
| 13. Move        | 26. And           | 39. Live (verb) |               |

**List 3A**

- |               |                |               |                 |
|---------------|----------------|---------------|-----------------|
| 1. Bill       | 14. Oil        | 27. When      | 40. On          |
| 2. Add (ad)   | 15. King       | 28. Book      | 41. If          |
| 3. West       | 16. Pie        | 29. Tie       | 42. Raw         |
| 4. Cute       | 17. He         | 30. So        | 43. Glove       |
| 5. Start      | 18. Smooth     | 31. Hand      | 44. Ten         |
| 6. Ears       | 19. Farm       | 32. End       | 45. Dull        |
| 7. Tan        | 20. This       | 33. Shove     | 46. Though      |
| 8. Nest       | 21. Done (dun) | 34. Have      | 47. Chair       |
| 9. Say        | 22. Use (yews) | 35. Owes      | 48. We          |
| 10. Is        | 23. Camp       | 36. Jar       | 49. Ate (eight) |
| 11. Out       | 24. Wool       | 37. No (know) | 50. Year        |
| 12. Lie (lye) | 25. Are        | 38. May       |                 |
| 13. Three     | 26. Aim        | 39. Knit      |                 |

**List 4A**

- |                   |                  |                |                    |
|-------------------|------------------|----------------|--------------------|
| 1. All (awl)      | 14. Leave        | 27. Art        | 40. Jump           |
| 2. Wood (would)   | 15. Of           | 28. Will       | 41. Pale (pail)    |
| 3. At             | 16. Hang         | 29. Dust       | 42. Go             |
| 4. Where          | 17. Save         | 30. Toy        | 43. Stiff          |
| 5. Chin           | 18. Ear          | 31. Aid        | 44. Can            |
| 6. They           | 19. Tea (tee)    | 32. Than       | 45. Through (thru) |
| 7. Dolls          | 20. Cook         | 33. Than       | 46. Clothes        |
| 8. So (sew)       | 21. Tin          | 34. Shoe       | 47. Who            |
| 9. Nuts           | 22. Bread (bred) | 35. His        | 48. Bee (be)       |
| 10. Ought (aught) | 23. Why          | 36. Our (hour) | 49. Yew            |
| 11. In (inn)      | 24. Arm          | 37. Men        | 50. Am             |
| 12. Net           | 25. Yet          | 38. Near       |                    |
| 13. My            | 26. Darn         | 39. Few        |                    |

**Children's Spondee List**

- |                |                |                |               |
|----------------|----------------|----------------|---------------|
| 1. Sidewalk    | 15. Mousetrap  | 29. Toothbrush | 43. Necktie   |
| 2. Birthday    | 16. Cowboy     | 30. Dishpan    | 44. Ash tray  |
| 3. Cupcake     | 17. Wigwam     | 31. Bathtub    | 45. Bedroom   |
| 4. Airplane    | 18. Coughdrop  | 32. Jackknife  | 46. Toy shop  |
| 5. Headlight   | 19. Churchbell | 33. Ice cream  | 47. Playpen   |
| 6. Blackbird   | 20. Sunset     | 34. Schoolroom | 48. Dollhouse |
| 7. Shotgun     | 21. Daylight   | 35. Backyard   | 49. Highchair |
| 8. Eyebrow     | 22. Footstool  | 36. Doorbell   | 50. Downtown  |
| 9. Railroad    | 23. Pancake    | 37. Drugstore  | 51. Meatball  |
| 10. Baseball   | 24. Hotdog     | 38. Streetcar  | 52. Sunshine  |
| 11. Stairway   | 25. Outside    | 39. Hopscotch  | 53. Barnyard  |
| 12. Armchair   | 26. Scarecrow  | 40. Jump rope  | 54. Bus stop  |
| 13. Playground | 27. Playmate   | 41. Shoelace   | 55. Football  |
| 14. Doorstep   | 28. Rainbow    | 42. Hairbrush  | 56. Bluejay   |
|                |                |                | 57. Birdnest  |

Blank page.





**VIASYS**<sup>TM</sup>  
HEALTHCARE  
*Excellence For Life*